



SY31-9054-5

**IBM System/36**  
**5363 System Unit**  
**Maintenance Information Manual**



SY31-9054-5

**IBM System/36**  
**5363 System Unit**  
**Maintenance Information Manual**

**Sixth Edition (September 1989)**

This major revision makes obsolete SY31-9054-4.

The drawings and specifications contained herein shall not be reproduced in whole or in part without the written permission of IBM.

IBM has prepared this maintenance manual solely for the use of IBM customer engineers and customer service representatives in the maintenance or repair of the specific machines discussed. IBM makes no claim that the manual is suitable for any other purpose.

Information contained in this manual is subject to change from time to time. Any such change will be reported in subsequent revisions or technical newsletters.

References in this publication to IBM products, programs, or services do not imply that IBM intends to make these products, programs, or services available in all countries in which IBM operates.

Publications are not stocked at the address given below. Direct requests for IBM publications to your IBM representative or to the IBM branch office that serves your area.

This publication may contain technical inaccuracies or typographical errors. To report an error, use the Reader's Comment Form at the back of the publication. If the form has been removed, address your comments to IBM Corporation, Information Development, Department 245, Rochester, Minnesota, U.S.A. 55901. IBM reserves the right to use or distribute the information you supply in any way it believes appropriate (without incurring any obligation to you).

---

## Preface

This manual contains the procedures and information necessary to service a System/36 with a 5363 System Unit. These procedures are specifically for the system and I/O attachments, controllers, adapters, and most devices attached to the system.

This manual uses a specific range of words so that the text can be understood by customer engineers in countries where English is not the normal language.

It is assumed that the hardware service representative using this manual has been trained on the IBM 5363 System Unit, as described in the *System/36—5363 New Product Planning Technical Service Letter*.

---

## About This Manual

This manual includes:

- A table of contents showing all the procedures in this manual, the reference number of each procedure, the procedure titles, and the page on which each procedure starts.
- A section contents page showing all procedures in the section.
- Eleven sections containing maintenance procedures.
- Three appendixes containing information about:
  - AC safety grounding.
  - Safety inspections.
  - Electrostatic discharge sensitive logic cards.
- A parts catalog containing part numbers and descriptions.
- A glossary of terms and abbreviations used in this manual.
- An index containing key words to procedures in this manual.

---

## Related Publications

### Customer/Operator Publications

- *Setting Up Your Computer—5363, SA21-9926*, contains procedures to:
  - Install the system
  - Attach work stations
  - Attach communications cables
- *Performing the First System Configuration for Your System—5363, SC21-9686*, contains information needed to configure a new system.
- *Operating Your Computer—5363, SC21-9685*, contains system operating procedures for:
  - Subconsole operators
  - System console operators
  - Alternative console operators
- *Using Your Display Station—5363, SC21-9692*, contains display operating procedures for:
  - Command display station operators
  - Data display station operators
- *System Messages, SC21-7938*, contains the system, licensed program, and utility program displayed messages, their causes, and their recovery procedures.
- *System Reference, SC21-9020*, contains information to perform tasks that use system commands, procedures, and OCL statements.
- *System Problem Determination—5363, SC21-9684*, contains error analysis information to isolate and determine the cause of system and communications problems.

## Service Publications

- *Program Service Manuals—5363 Addendum*, LY21-0902, contains addendums to the following IBM System/36 manuals:
  - *System Data Areas*, LY21-0592, containing information to support SSP problem diagnosis, including:
    - Data area descriptions
    - Feature support information for programming languages and utilities
  - *Control Storage Service Information*, LY31-0650, containing information to:
    - Analyze microcode problems
    - Make microcode temporary fixes
- *Program Problem Diagnosis and Diagnostic Aids—5363 Addendum*, SY21-0903, is an addendum to the IBM System/36 manual, *Program Problem Diagnosis and Diagnostic Aids*, SY21-0593 which contains aids for diagnosing SSP problems.
- *Functions Reference Manual—5363 Addendum*, SA21-9934, is an addendum to the IBM System/36 manual, *Functions Reference Manual*, SA21-9436, which contains information needed to understand the system from a hardware point of view, including:
  - System instructions
  - Status bytes
  - Controls and indicators
  - Device characteristics
- *5363 System Reference Codes (SRC)*, SY31-9055, contains valid SRCs with probable failing FRUs, FRU part numbers, and MIM references.



# **Safety**

---

## **Danger, Caution and Warning Notices**

### **Danger Notices in This Manual**

A danger notice calls attention to a situation that is potentially lethal or extremely hazardous to persons.

### **Caution Notices in This Manual**

A caution notice calls attention to an action that could cause harm to persons. There are no caution notices in this manual.

### **Warning Notices in This Manual**

A warning notice calls attention to an action that could cause damage to a program, device, system, or data.



# **Contents**

<b>Section 1. System Entry and FRU Isolation Procedures</b>	<b>1-1</b>
<b>Section 2. Overviews and Locations Procedures</b>	<b>2-1</b>
<b>Section 3. General Procedures</b>	<b>3-1</b>
<b>Section 4. Power Procedures</b>	<b>4-1</b>
<b>Section 5. Control Panel Procedures</b>	<b>5-1</b>
<b>Section 6. Diskette Procedures</b>	<b>6-1</b>
<b>Section 7. Local Work Station Procedures</b>	<b>7-1</b>
<b>Section 8. Disk Procedures</b>	<b>8-1</b>
<b>Section 9. Communications Procedures</b>	<b>9-1</b>
<b>Section 10. Tape Drive Procedures</b>	<b>10-1</b>
<b>Section 11. Local Area Network Procedures</b>	<b>11-1</b>
<b>Appendix A. AC Safety Grounds</b>	<b>A-1</b>
<b>Appendix B. Safety Inspection Guide</b>	<b>B-1</b>
<b>Appendix C. Working with ESD-Sensitive Cards</b>	<b>C-1</b>
<b>Appendix D. Glossary</b>	<b>D-1</b>
<b>Appendix E. Parts Catalog</b>	<b>E-1</b>
<b>Part Number Index</b>	<b>E-19</b>
<b>Appendix F. Service Log</b>	<b>F-1</b>
<b>Index</b>	<b>X-1</b>



---

## **Section 1. System Entry and FRU Isolation Procedures**

- 103 How to Determine What Level System You Have 1-2
- 105 System Entry Procedure 1-5
- 160 Isolating Main Storage Problems 1-13

---

## 103 How to Determine What Level System You Have

### Level 0 Systems

Level 0 systems are identified by logo plates on the front and back of the machine which have a smooth surface and the characters "IBM 5363."

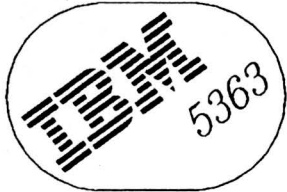

Level 0 System Logo

R36B164-0

### Level I Systems

Level I systems are identified by logo plates on the front and back of the machine which have raised letters and the characters "IBM 5363 I."

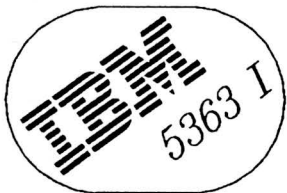

Level I System Logo

R36B166-0

### Level II Systems

Level II systems are identified by logo plates on the front and back of the machine which have raised letters and the characters "IBM 5363 II."

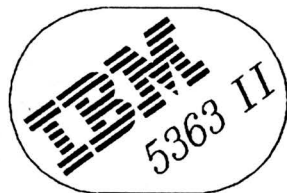

Level II System Logo

R36B167-0

### Level III Systems

Level III systems are identified by logo plates on the front and back of the machine which have raised letters and the characters "IBM 5363 III " or "IBM Application System/Entry 5363 III."

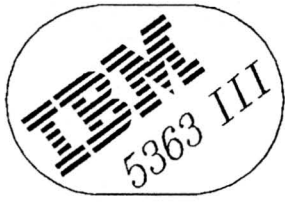

Level III System Logo

R36B172-0

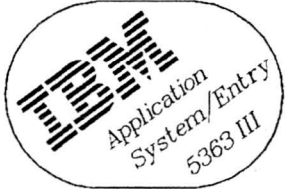

Level III System Logo

R36B174-0

### Level IV Systems

Level IV systems are identified by logo plates on the front and back of the machine which have raised letters and the characters "IBM 5363 IV" or "IBM Application System/Entry 5363 IV."

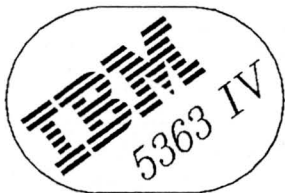

Level IV System Logo

R36B173-0

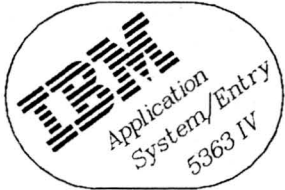

Level IV System Logo

R36B175-0

The following table shows what combinations of these FRUs can be used in each level of system unit.

Level 0 5363	Level I 5363 I	Level II 5363 II	Level III 5363 III	Level IV 5363 IV	FRU and Part Number
X					Base Power Supply (1035350)
X	X	X	X	X	Base Power Supply I/II (1035807)
X					Feature Power Supply (1035395) (Europe, Middle East, and Africa (1035526))
X	X	X	X	X	Feature Power Supply I/II (1035808) (Europe, Middle East, and Africa (1035809))
X					A1 Board (92X7333/92X7335)
X	X	X	X	X	A1 Board I/II (92X7243/92X7396)
X	X		X		Work Station Adapter/Control Panel Interface Card (92X3221)
		X		X	Work Station Adapter/Control Panel Interface Card (92X7255)
X	X				Disk Adapter (92X3224)
		X	X	X	Disk Adapter II (92X9256)
		X		X	Data Storage Adapter II Card (92X6495)
X	X	X			Main Storage Card 1-MB (92X3222)
			X	X	Main Storage Card 1-MB (21F4225)
X	X	X			Main Storage Card 2-MB (92X7231)
			X	X	Main Storage Card 2-MB (21F4226)

---

## 105 System Entry Procedure

### Notes:

1. Read and observe all safety procedures before servicing the system.
  2. Unless instructed not to, always power off the 5363 before removing, exchanging, or installing a FRU.
  3. Ensure that the customer problem determination (PD) procedures have been completed before you continue with these procedures. The PD procedures may supply additional information about the problem.
  4. Use this entry procedure only if SRCs have failed to isolate the problem. While using this procedure, do not use any SRCs unless instructed to do so.
- 

1. Ensure that the Security switch is in the Service position.
2. Power on the 5363.
3. If the system will not power on, go to "420 Power Supply FRU Isolation Procedure" on page 4-6.
4. If the control panel does not appear to function, go to "505 Control Panel Symptom Table" on page 5-2.
5. If the System Support Program Product (SSP) is installed, go to step 7.  
If not, continue with step 6.
6. To load SSP from diskette, go to "322 Reloading the SSP Diskettes" on page 3-9.  
If not, continue with step 7.
7. Load the system from disk:  
Power off the 5363, wait 20 seconds, power on the 5363.
  - a. Select function 1 (IPL).
  - b. Enter FF00.
  - c. Press the Start Function key.If the IPL Sign On prompt appears, continue with step 8.  
If not, go to step 13.
8. Load the system from disk:  
Power off the 5363, wait 20 seconds, power on the 5363.
  - a. Select function 1 (IPL).
  - b. Enter 0000.
  - c. Press the Start Function key.If the IPL Sign On prompt appears, continue with step 9.  
If not, go to step 15.
9. Run ERAP ("360 Getting ERAP Reports" on page 3-25).  
If SRCs are recorded in ERAP, go to step 12.  
If no SRCs are recorded, continue with step 10.
10. Run SYSTEST for 10 minutes ("328 Service Procedures under SSP" on page 3-11). Follow the prompts to select the devices that you want to run during SYSTEST.  
If an SRC is displayed in the 4-character display, use it to isolate the problem.  
Analyze any errors that occur during SYSTEST ("360 Getting ERAP Reports" on page 3-25) to determine which device is failing. Continue with step 12.

If no SRC is displayed or if no errors occur, go to step 11 and continue from there for the device you suspect is failing.

11. If the device is:
  - a. Disk, go to "Procedure 121" on page 1-8.
  - b. Work station, go to "Procedure 122" on page 1-10.
  - c. Main storage processor, go to "Procedure 123" on page 1-10.
  - d. Communications, go to "Procedure 124" on page 1-10.
  - e. Diskette, go to "602 Isolating Diskette Drive Problems" on page 6-2.
  - f. Control panel, go to "505 Control Panel Symptom Table" on page 5-2.
  - g. Tape, go to "Procedure 125" on page 1-10.
  - h. Local area network, go to "Procedure 126" on page 1-11.
  - i. Other, go to "Procedure 120" on page 1-7.
12. Analyze any SRCs that are logged in ERAP near the time of the customer-reported problem to determine which device is failing. If the indicated device is:
  - a. Disk, go to "803 Analyzing Disk Drive ERAP" on page 8-4.
  - b. Work station, go to "Procedure 132" on page 1-11.
  - c. Communications, use the SRCs in the report to isolate the problem.

If the problem is repaired, this procedure is complete.

If not, go to "910 Isolating Communications Problems" on page 9-2.
  - d. Diskette, use the SRCs in the report to isolate the problem.

If the problem is repaired, this procedure is complete.

If not, go to "602 Isolating Diskette Drive Problems" on page 6-2.
  - e. CSP/Channel, go to "Channel Isolation Procedure 155" on page 1-12.
  - f. Tape, use the SRCs in the report to isolate the problem.

If the problem is repaired, this procedure is complete.

If not, go to "Procedure 125" on page 1-10.
13. Load the system from diskette 61:

Power off the 5363, wait 20 seconds, power on the 5363.

  - a. Select function 3 (IPL Diagnostic Diskette).
  - b. Enter FF00.
  - c. Press the Start Function key.

If the DCP Main menu appears, go to step 15.

If not, continue with step 14.
14. Go to "Channel Isolation Procedure 155" on page 1-12.
15. Load the system from diskette 61:

Power off the 5363, wait 20 seconds, power on the 5363.

  - a. Select function 3 (IPL Diagnostic Diskette).
  - b. Enter 0000.
  - c. Press the Start Function key.

**Note:** This IPL may take 15 minutes.
16. Use the SRC to isolate the problem.

If the SRC does not isolate the problem, go to "Channel Isolation Procedure 155" on page 1-12.

If the SRC does isolate the problem, this procedure is complete.

## Procedure 120

1. Display the Error History Table to see if a FRU is identified by any SRC's that are shown ("360 Getting ERAP Reports" on page 3-25).
2. Power off the 5363.
3. Go to "305 Cover Removal" on page 3-2.
4. Ensure that the internal cables are in the correct position, and are kept away from external covers.
5. Reseat all cards and cables to give better contact points.
6. Power on the system.
7. Ensure that the system frame is grounded to a service ground and that the AC input voltage is inside the tolerance. (See the manual *Setting Up Your Computer—5363*, SA21-9926, for correct grounding and voltage information.) Verify that the system's DC voltages are correct. See "435 DC Voltage Distribution" on page 4-11.
8. Power off the 5363.
9. Reinstall the 5363 covers, go to "305 Cover Removal" on page 3-2.
10. Load the system from disk.
  - a. Select function 1 (IPL).
  - b. Enter 0000.
  - c. Press the Start Function key.
11. Run SYSTEST for 5 minutes, go to "328 Service Procedures under SSP" on page 3-11. Follow the prompts to select the devices that you want to run during SYSTEST.
12. Analyze any errors that occur during SYSTEST. See "360 Getting ERAP Reports" on page 3-25.

If errors occur, use the SRC to isolate the problem.

If no errors occur, this procedure is complete.

### Notes:

1. Verify that the voltage switches located on the system power supplies at the rear of the system are set to the correct voltage for your location.
2. Intermittent power problems, which can be caused by excess ripple on the AC power line or by failures of the base or feature power supplies, can cause the following system conditions:
  - If the Security switch is in the Normal position, an IPL is performed and the IPL Sign On display appears on the system console.
  - If the Security switch is in the Locked position, the control panel has **only** the Power On and Output Display lights on.
  - If the Security switch is in the Service position, the control panel contains a 1 in the Function display and 0000 in the 4-character display.

If these conditions have occurred and you have verified that the AC power is good, exchange the following FRUs in the order shown:

- Feature power supply (if present)
- Base power supply

## Procedure 121

Perform the action for the symptom that best describes the type of failure.

Symptom	Action
<p>Intermittent disk errors.</p> <p><b>Note:</b> A disk utility is available to analyze intermittent disk problems. For 5363, the disk utility is on diskette 60 (IBM part 6274373). For 5363 I, II, III, and IV, the disk utility is on diskette 61.</p>	<ol style="list-style-type: none"><li>1. Analyze ERAP for disk SRCs. If an SRC is present, perform the procedure indicated by the SRC. Use procedure "803 Analyzing Disk Drive ERAP" on page 8-4 for more information on analyzing disk drive ERAP. If this does not solve the problem continue with step 2.</li><li>2. Power off the 5363.</li><li>3. Remove the 5363 cover ("305 Cover Removal" on page 3-2).</li><li>4. Reseat the cards and cables in the 5363, go to "220 Board Locations" on page 2-9.</li><li>5. Reinstall the 5363 cover.</li><li>6. Power on the 5363.</li><li>7. Perform an IPL of the 5363 from disk, select function 1, enter 0000.</li></ol> <p>If an SRC is displayed, perform the procedure that matches the SRC.</p> <p><b>Note:</b> If the FRU indicated is a disk drive, perform the Disk Drive Reload procedure on this page.</p> <p>Run SYSTEST for 10 minutes to verify the problem is fixed ("328 Service Procedures under SSP" on page 3-11) and ("360 Getting ERAP Reports" on page 3-25).</p>
<p>Multiple CAxx SRCs.</p>	<p>Go to procedure "801 Multiple CAxx SRCs (5363 II and IV only)" on page 8-2.</p>
<p>Permanent disk error. Cannot perform an IPL from disk.</p> <p>An SRC indicates that the disk drive is defective.</p>	<p>Before performing a disk drive reload, go to "804 Disk Drive Analyze Procedure" on page 8-5, then perform the Disk Drive Reload procedure to verify that the failure is not caused by bad data on the 5363 disk drive.</p> <p>If the Disk Drive Reload procedure does not solve the problem, perform the procedure that matches the SRC.</p>

Run SYSTEST for 10 minutes to verify any exchanged FRU ("328 Service Procedures under SSP" on page 3-11).

## Disk Drive Reload

This procedure is used to determine if the disk drive A failure is caused by bad system microcode, bad SSP code, or bad data.

1. **Reload the system microcode and perform an IPL from disk. See the following:**
  - a. "312 Performing a System Reset" on page 3-7.
  - b. "321 Auto Configuring the System" on page 3-8.

If an SRC is displayed, perform the procedure indicated by the SRC. If the IPL is not successful, go to step 2 on page 1-9. If the IPL is successful, run system test to verify that the problem is fixed. Go to "328 Service Procedures under SSP" on page 3-11.

**2. Reload the SSP diskettes and perform an IPL from disk. See the following:**

- a. Reference procedure "322 Reloading the SSP Diskettes" on page 3-9.

If an SRC is displayed or if the IPL is not successful, continue with the next action. If the IPL is successful, run system test to verify that the problem is fixed. Go to "328 Service Procedures under SSP" on page 3-11.

**Notes:**

- a. The customer's data will be destroyed if you initialize the disk. To minimize the possible damage to customer data, read the following note.
  - b. An alternative method to initializing disk drive A is to exchange the disk drive logic board "804 Disk Drive Analyze Procedure" on page 8-5 or to install a new disk drive "804 Disk Drive Analyze Procedure" on page 8-5 before performing step 3. If the new disk drive fails, use the list of FRUs at the end of this procedure to isolate the problem. It may be necessary to reinstall the removed FRU and attempt to initialize the disk to remove customer data.
- 3. Initialize disk drive A, reload the system microcode to disk, reload the SSP diskettes to disk, and perform an IPL.**

- a. Insert diskette 61 in the 5363 diskette drive. Perform an IPL of the 5363 using a select function 3, enter a code of 22FF, and press the Start Function key.
- b. Select the option to initialize the disk. Follow the prompts.
- c. Reload the 5363 microcode ("324 Reloading the System Microcode Without Auto Configure" on page 3-9).
- d. Load SSP reference procedure ("322 Reloading the SSP Diskettes" on page 3-9).
- e. Perform an IPL of the 5363 from disk using a select function 1, enter a code of 0000, and press the Start Function key.

If the IPL is successful, run system test to verify that the problem is fixed ("328 Service Procedures under SSP" on page 3-11).

If an SRC indicated that the disk drive is the failing FRU, install a new drive. The following FRUs can cause IPL failures:

- Disk drive
- Disk adapter card (A1C2)
- Disk adapter card (A1A2) (5363 II and IV)
- Data storage adapter card (A1D2)
- Data storage adapter card (A1B2) (5363 II and IV)
- Disk cable assembly
- Control storage processor card (A1G2)
- A1 board
- Main storage processor cards (A1H2 and A1J2)

## Procedure 122

1. Power off the 5363.
2. Ensure that the connectors on the twinaxial cables between the system port and the work stations are tight and that the cables are correctly installed (not made into a coil or hung on the wall) ("714 Local Work Station Cable Ohmmeter Test" on page 7-15) and ("710 Local Work Station Cable Signal Quality Check" on page 7-3).
3. Ensure that the work stations are grounded to a service ground ("706 Local Work Station Network Analysis Procedure" on page 7-2).
4. If you have found and corrected a problem, this procedure is complete.  
If not, go to "Procedure 120" on page 1-7.

## Procedure 123

Load the system from diskette 61:

1. Select function 3 (IPL Diagnostic Diskette).
2. Enter FC03.
3. Press the Start Function key.
4. Run the test for 10 minutes.

FC03 will appear on the panel when main storage diagnostics have successfully completed. If an SRC other than FC03, is displayed, exchange the FRU indicated and then run SYSTEST for 10 minutes to verify any exchanged FRU ("328 Service Procedures under SSP" on page 3-11).

If not, go to "Procedure 120" on page 1-7.

## Procedure 124

1. Run COMMTEST ("328 Service Procedures under SSP" on page 3-11) and follow the recommended actions displayed.
2. Ensure that all external modems are connected to a service ground.
3. If the problem is repaired, this procedure is complete.  
If not, go to "Procedure 120" on page 1-7.

## Procedure 125

1. Power off the 5363.
2. Reseat the tape adapter feature card located in the B1 board.
  - a. Tape adapter cable at B1-F see "B1 Board (Feature Machines)" on page 2-13.
  - b. Tape unit cable at the tape adapter connector.
3. Load the system from disk.
4. Power on the 5363.
  - a. Select function 1 (IPL).
  - b. Enter 0000.
  - c. Press the Start Function key.

5. Run on-line problem determination.
  - a. Key in PROBLEM and press the Enter key.
  - b. Select the Magnetic Tape option.
  - c. Follow the prompts.

### **Procedure 126**

1. Run on-line problem determination:
  - a. Key in PROBLEM and press the Enter key.
  - b. Select the Local Area Network option.
  - c. Follow the prompts.

### **Procedure 132**

1. Exchange any FRU indicated by the SRCs that you have not already exchanged.

If the failure is still present, check for the following:

- a. Work station (display or printer) problem ("706 Local Work Station Network Analysis Procedure" on page 7-2). (See the suitable work station maintenance manual.)
- b. Bad twinaxial cable: Check both ends for a good connection ("714 Local Work Station Cable Ohmmeter Test" on page 7-15) and ("710 Local Work Station Cable Signal Quality Check" on page 7-3).

If the problem is repaired, this procedure is complete.

If not, go to "Procedure 122" on page 1-10.

## Channel Isolation Procedure 155

In the 5363 machine, there are six devices which connect to the System/36 system channel. They are:

- Control storage processor (CSP) A1G2
- A1 system board
- Data storage adapter card A1D2
- Data storage adapter card A1B2 (5363 II and IV)
- Either work station controller A1E2, or the work station adapter/control panel interface A1F2
- Main storage card B1-G. (This could be installed in the B1 feature board).

### Diagnostic Procedure

**Note:** Unless instructed not to, always power off the 5363 before removing, exchanging, or installing a FRU.

1. Remove the following cards from the 5363 system:
  - a. Data storage adapter card (A1B2) (5363 II and IV), if installed
  - b. Data storage adapter card (A1D2)
  - c. Either work station controller or work station pass-through (A1E2)
2. IPL the system with wraps (1-0000). If an E0XX SRC is displayed, either the CSP (A1G2), Main Storage card (B1-G), or A1 board is defective. Suspect the following FRUs:

%	FRU
70	A1G2 CSP
25	B1-G Main Storage Card
5	A1 Board

If a 2100 SRC is displayed, continue with the next step.

3. Reinstall the data storage adapter card (A1D2).
4. IPL the system with wraps (1-0000). If a DC92 SRC is displayed and the machine is not a 5363 II or IV, continue with step 7 on page 1-13. If a C990 SRC is displayed and the machine is a 5363 II or IV, continue with step 5. If an SRC other than DC92 or C990 is displayed, either the data storage adapter card (A1D2) or the control store processor (A1G2) is defective. Suspect the following FRUs.

%	FRU
75	A1D2 Data Storage Adapter
25	A1G2 Control Store Processor

5. Reinstall the data storage adapter card (A1B2) (5363 II or IV) and top card connector.
6. IPL the system with wraps (1-0000). If a CF65 SRC is displayed, continue with step 7 on page 1-13. If not, the data storage adapter card (A1B2) (5363 II or IV) is defective.

7. Reinstall the work station card (A1E2). IPL the 5363 with wraps (1-10000). If the sign on screen does not appear, one of the following conditions exist:
  - a. Expanded work station configuration. The work station controller card (A1E2) is defective.
  - b. Base work station configuration. Either the work station pass-through card (A1E2), or the work station adapter/control panel interface card (A1F2) is defective.
  - c. Suspect the following FRUs:

%	FRU
95	A1F2 Work station adapter
5	A1E2 Work station pass-through card.

## B1 Feature Board FRU Isolation Procedure 156

1. Unplug all feature cards from the B1 board except for the IOP feature card (B1-A) and the main storage card (B1-G). IPL the system with wraps (1-0000). If an SRC of 6300 through 6355 is displayed on the system console, the following FRUs are suspect:
  - IOP feature card B1-A
  - Main storage card B1-G
  - Feature power supply
  - B1 feature board

If an SRC in the range indicated above is not displayed on the system console, continue with step 2.
2. Install the feature cards, one at a time. IPL the system with wraps (1-0000). If an SRC in the range of 6300 to 6355 is displayed on the system console, the feature card just installed is defective.
3. Repeat step 2 for each feature card until the failing card has been isolated.

---

## 160 Isolating Main Storage Problems

**Note:** Unless instructed not to, always power off the 5363 before removing, exchanging, or installing a FRU.

If an SRC indicates a Main Storage error, perform the following procedure:

1. Exchange the main storage card. (B1-G)
2. Load the system from Diskette 61:
  - a. Select function 3 (IPL Diagnostic Diskette).
  - b. Enter FA03.
  - c. Press the Start Function key.
3. Wait until the output display light is on with FA03 displayed. If a failure occurs, continue with step 4. If no failure occurs, go to "105 System Entry Procedure" on page 1-5.
4. Repeat steps 1 through 3 exchanging the following FRUs in this sequence:
  - a. A1J2 (MSP Data Flow)
  - b. A1H2 (MSP Control)
5. If a failure still occurs, either the A1 or B1 board is defective.



---

## **Section 2. Overviews and Locations Procedures**

205	System Overview	2-2
210	Power Overview	2-7
215	System Locations	2-8
220	Board Locations	2-9

## 205 System Overview

The diagram on this page shows an overview of the system. The following pages have expanded overviews of this diagram.

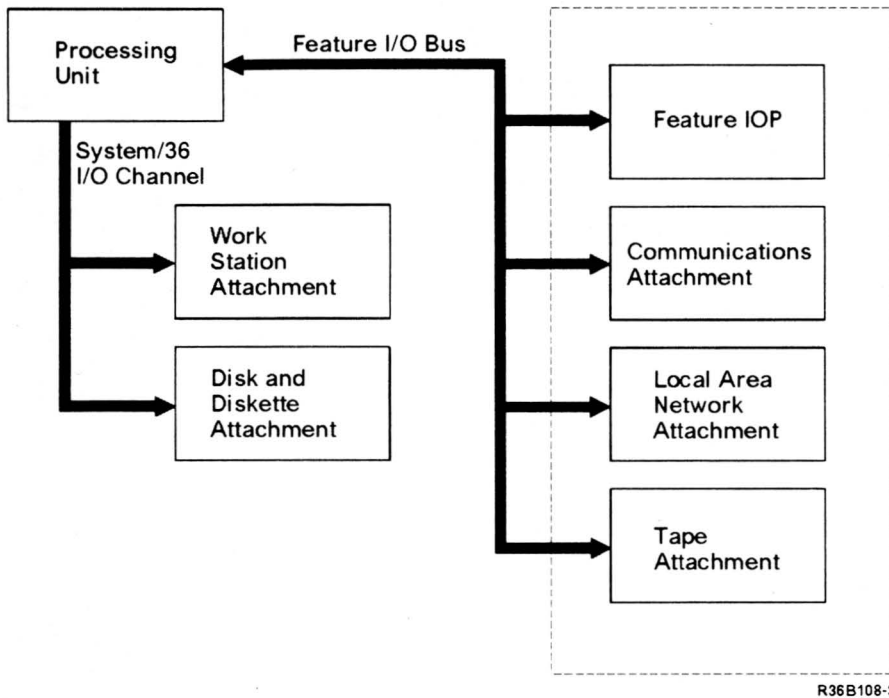

# Processing Unit and Channel Overview

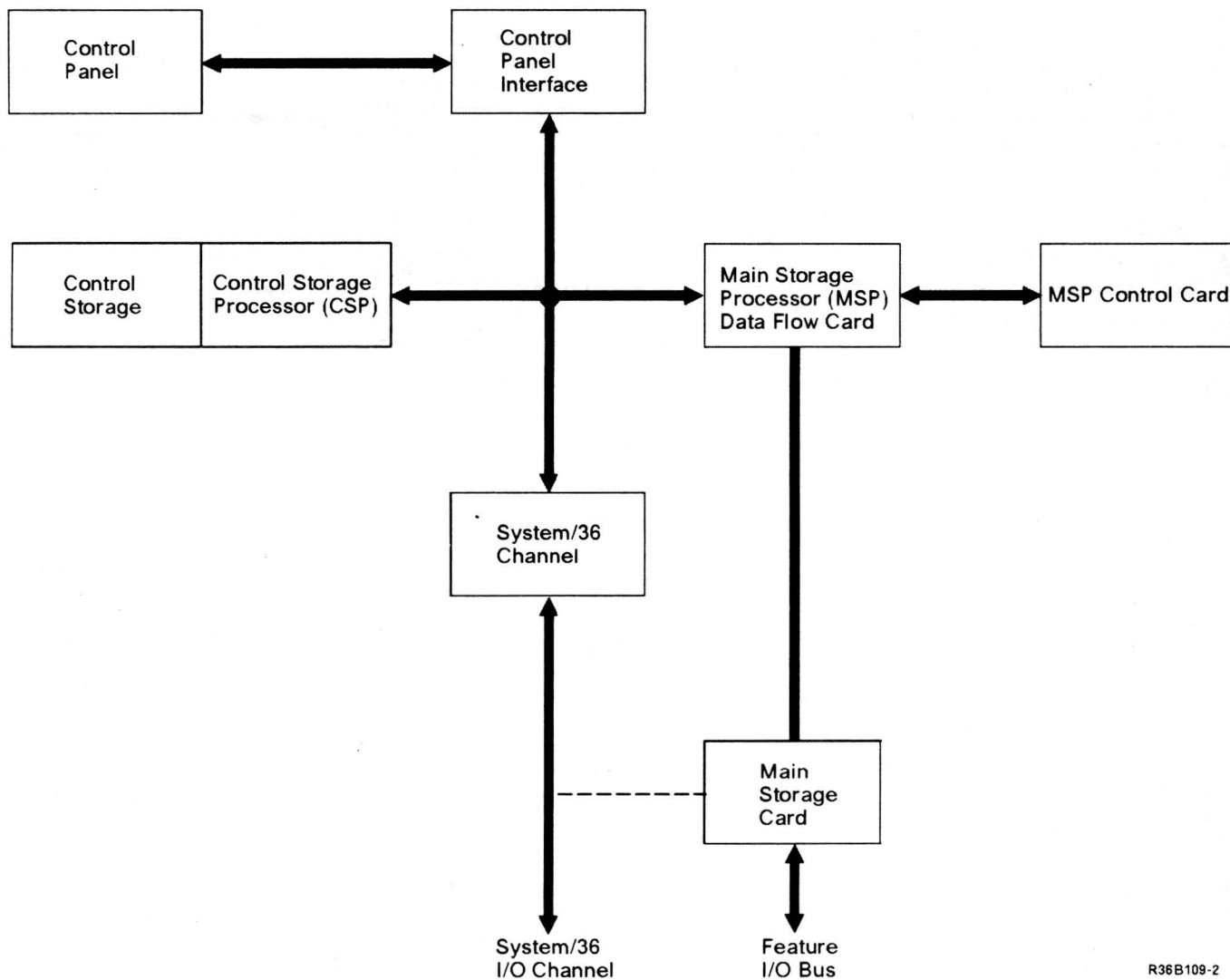

R36B109-2

## Work Station Attachment Overview

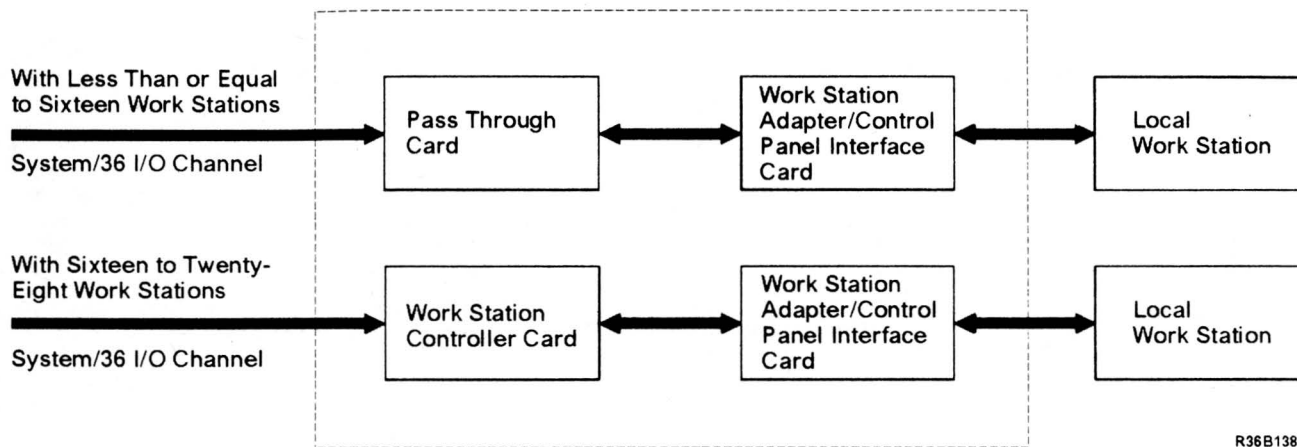

R36B138-2

# Diskette, Disk Attachment Overview

5363, 5363 I, or 5363 III

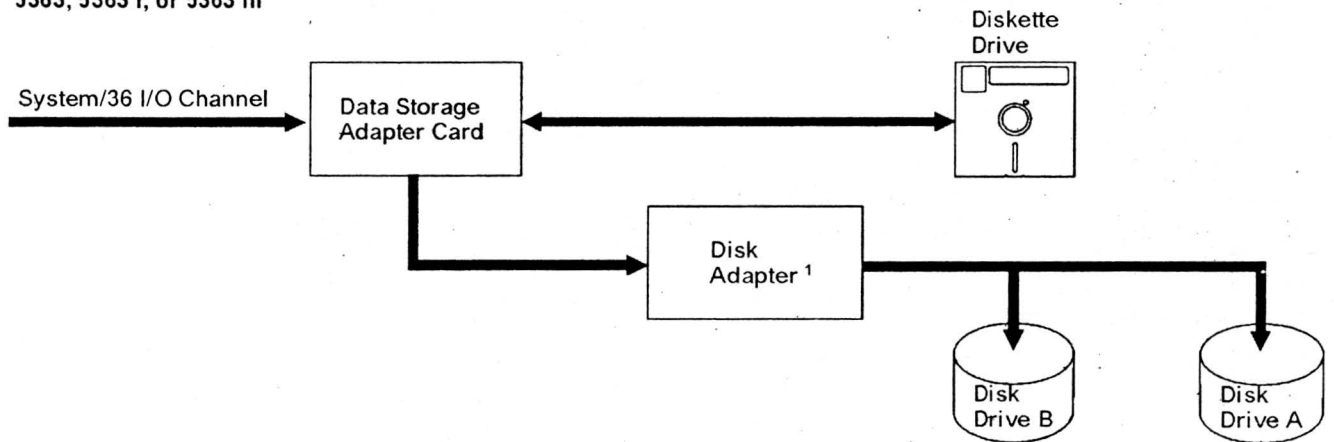

5363 II or 5363 IV

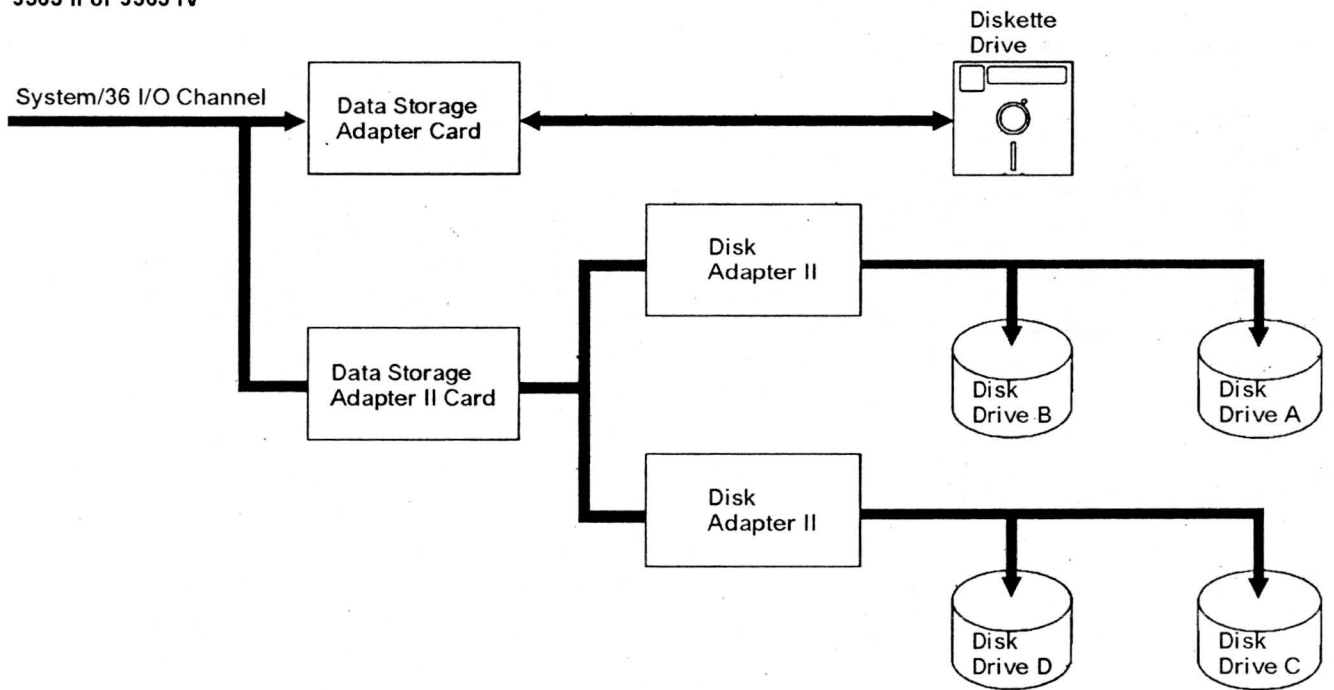

<sup>1</sup> 5363 III uses Disk Adapter II

R36B139-7

## Feature I/O Bus Attachment Overview

Feature BUS

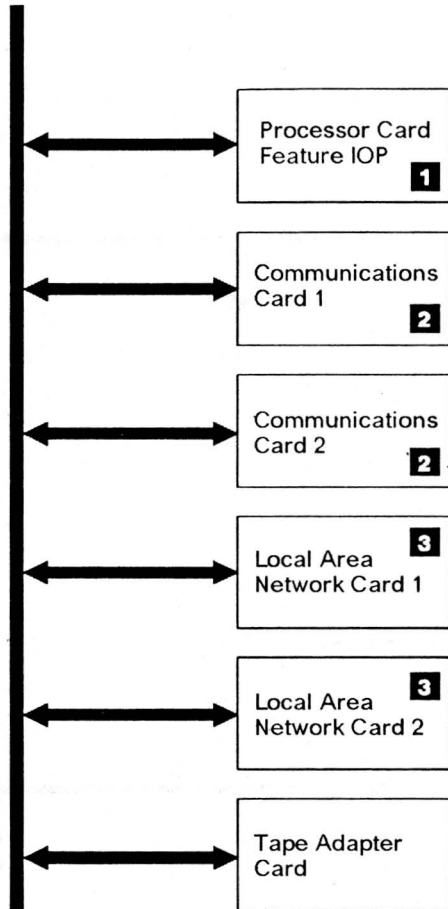

**1** This card is required in order to add any of these I/O features.

**2** Communication features include the following:

- a. IBM Realtime Interface Co-Processor
- b. SDLC
- c. BSC
- d. ASYNC
- e. X.25
- f. V.35

**3** Local Area Network is IBM Token Ring.

R36B140-4

## 210 Power Overview

The system power supply generates the DC voltages needed by the system and by the devices located inside the system. The following diagram shows the FRUs that receive AC and DC voltages from the power supply. For point-to-point power flow, see "435 DC Voltage Distribution" on page 4-11.

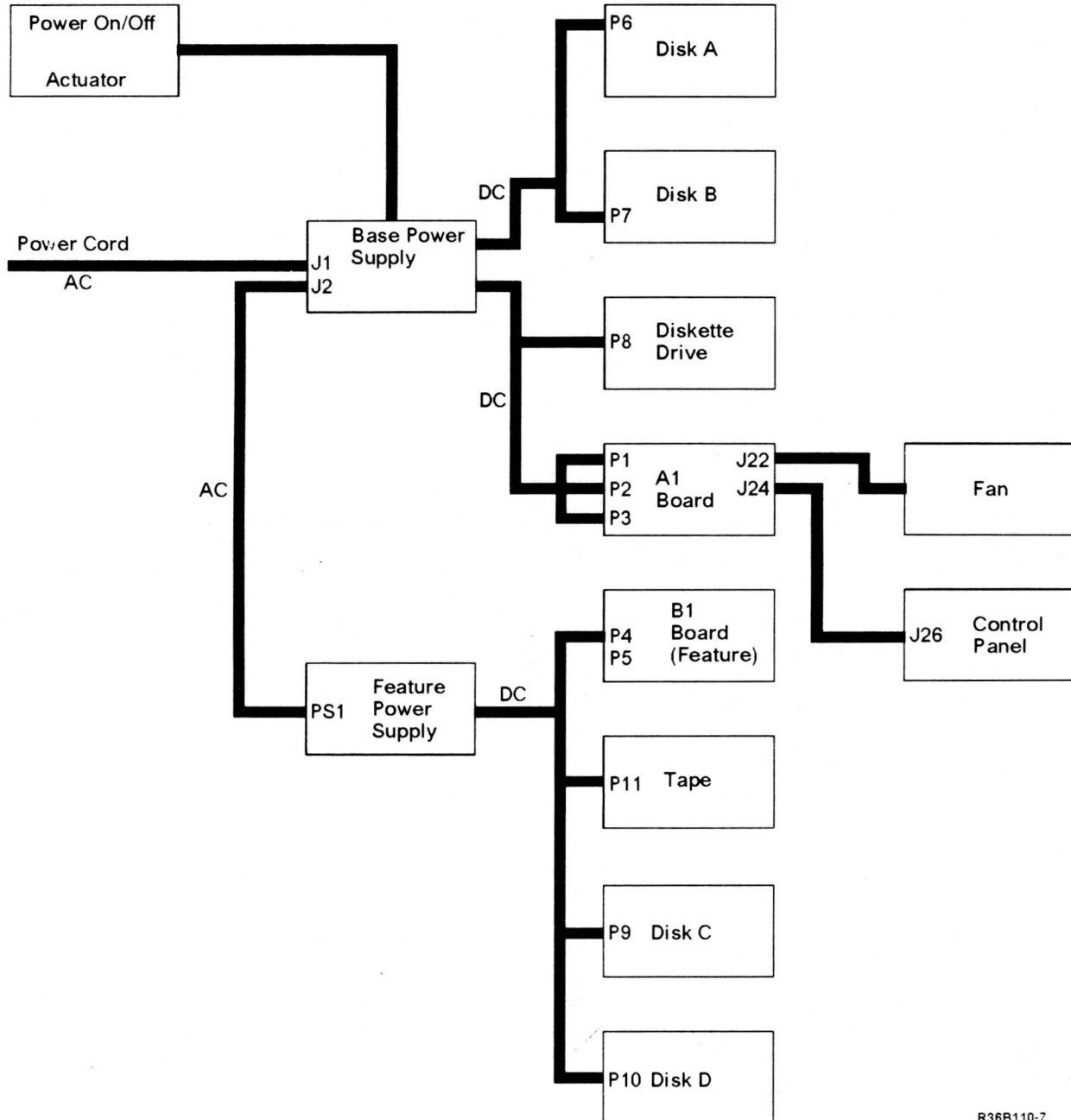

R36B110-7

# 215 System Locations

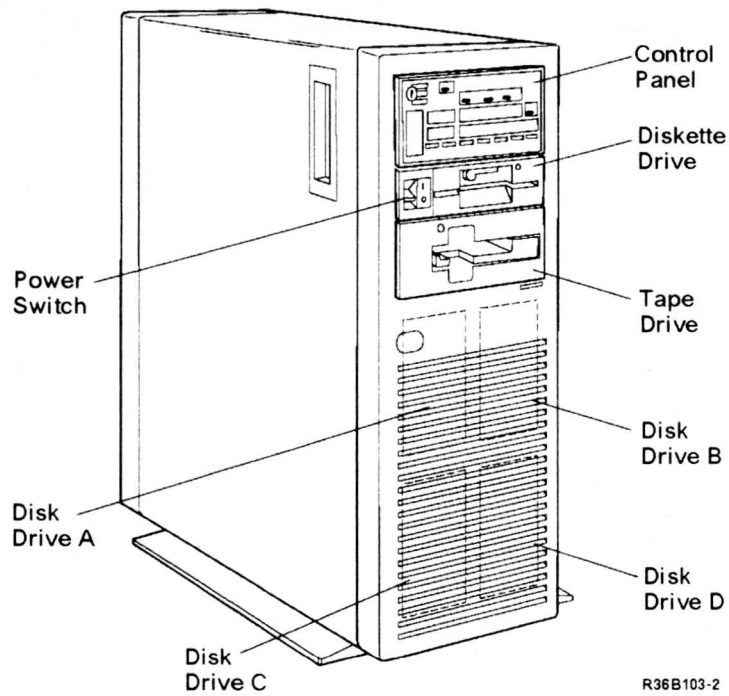
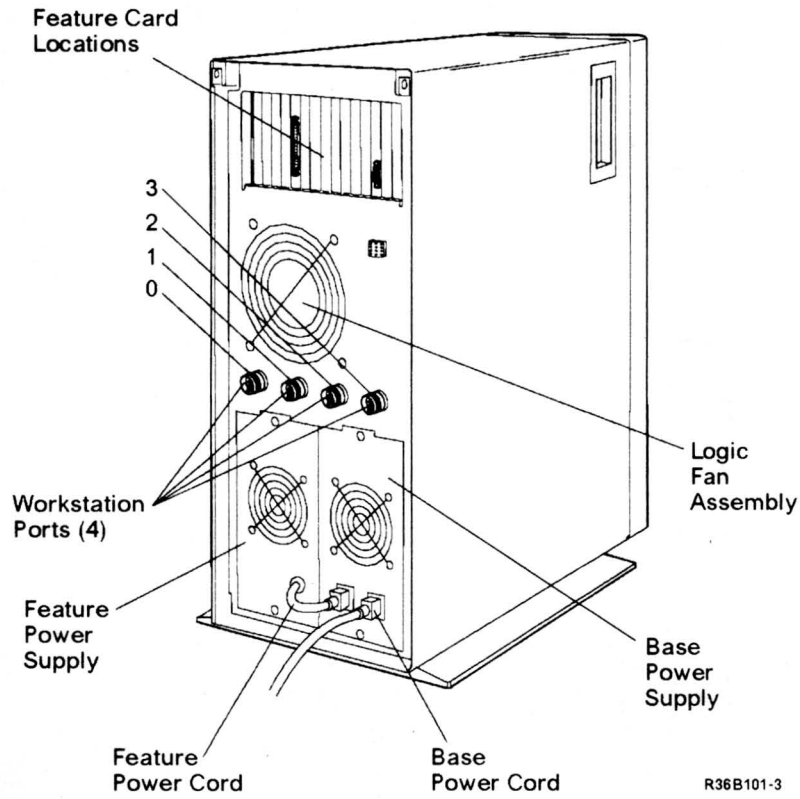

## 220 Board Locations

### A1 Board on a 5363, 5363 I, or 5363 III

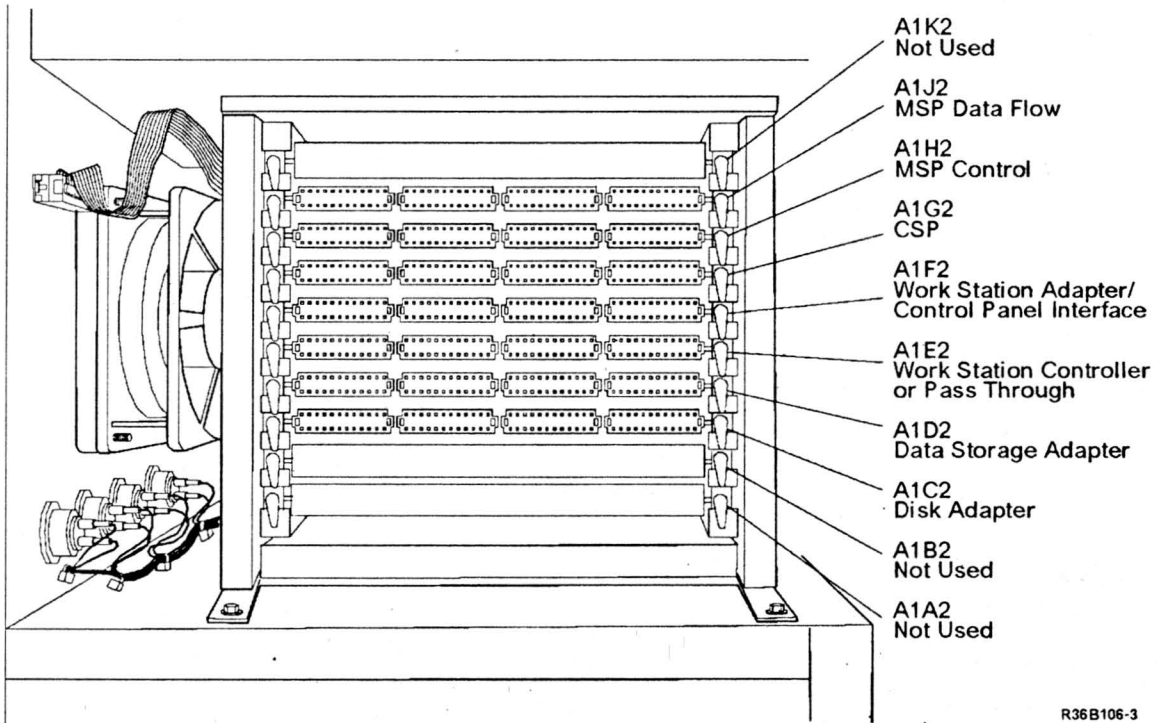

R36B106-3

### A1 Board on a 5363 II or IV

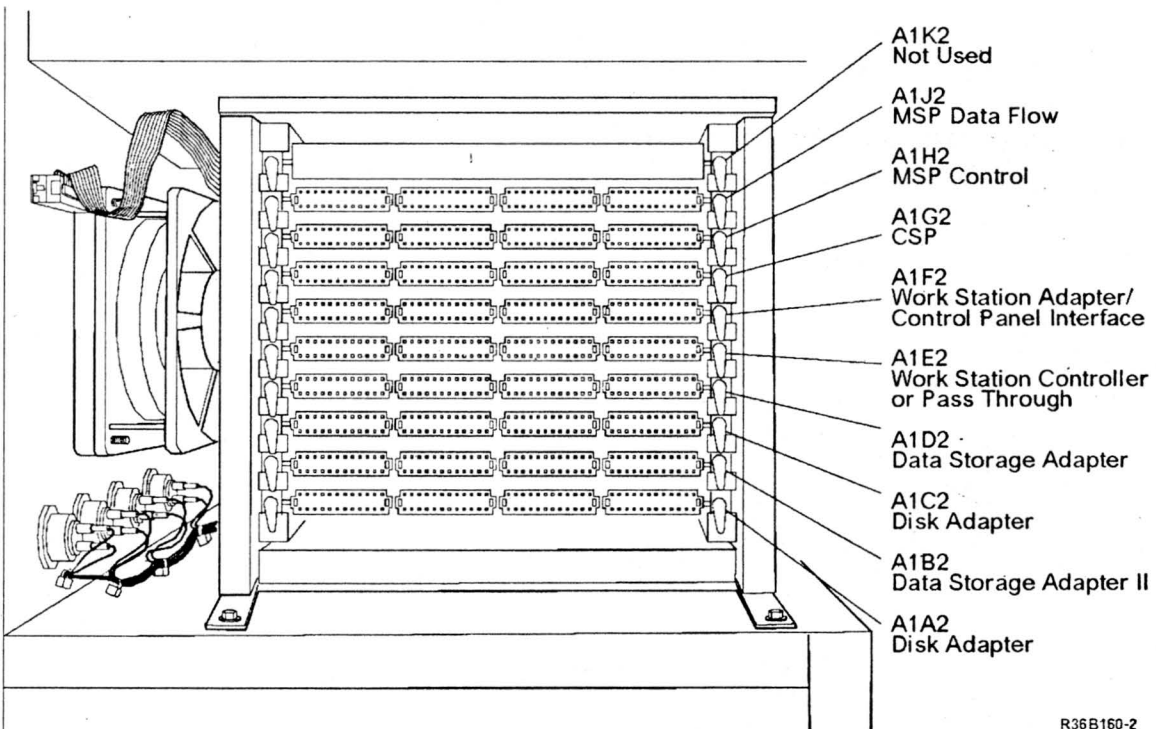

R36B160-2

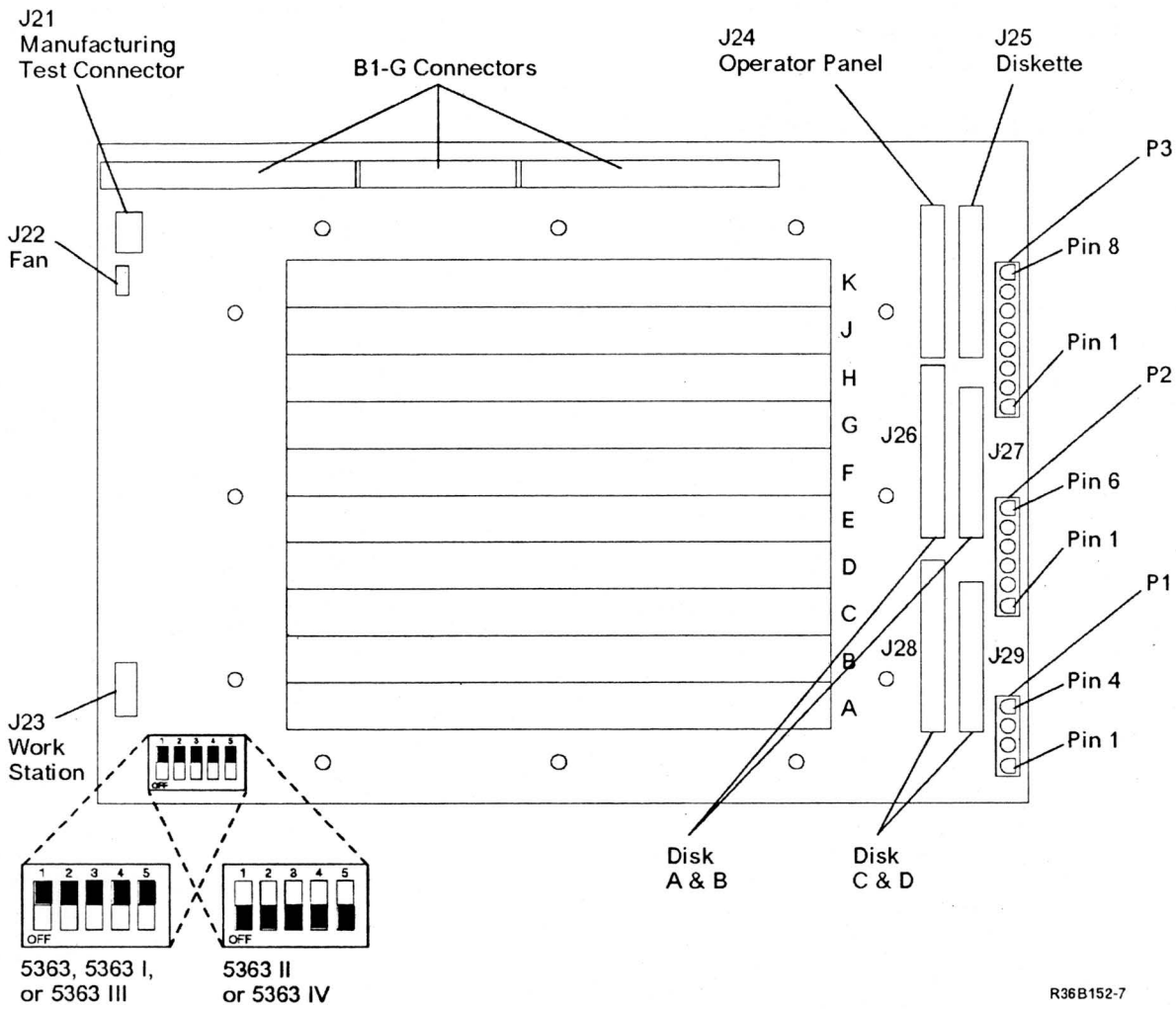

R36B152-7

**Note:** The switches in the lower left corner of the above figure are set at the factory. Check to be sure the switches are set as shown. The dark area indicates where the switch is pushed down.

### Main Storage Card (Base Machines) Top View

**Note:** B1-G is a B1 Board Socket, located on the A-A1 Board.

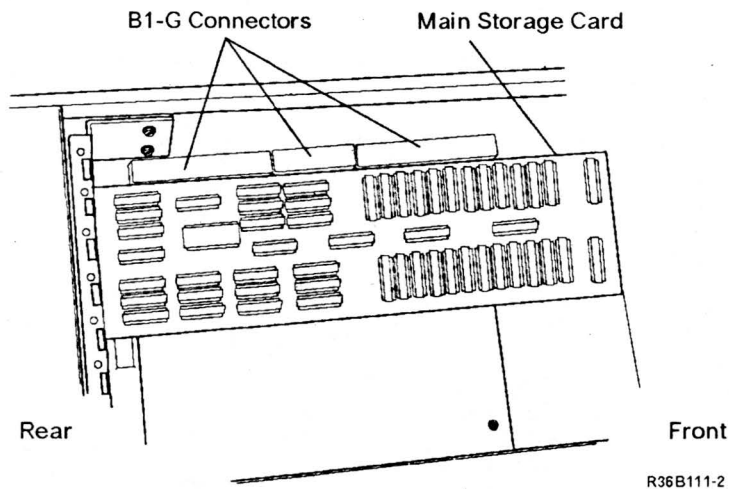

R36B111-2

# Top Card Connectors on a 5363, 5363 I, or 5363 III

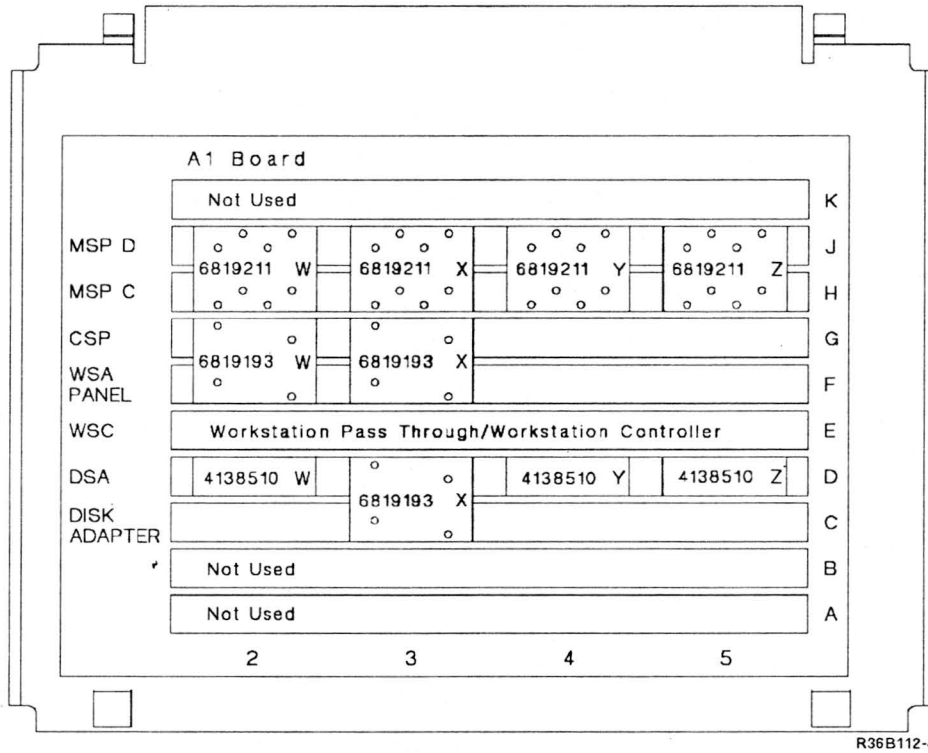

## Top View with Cover Removed

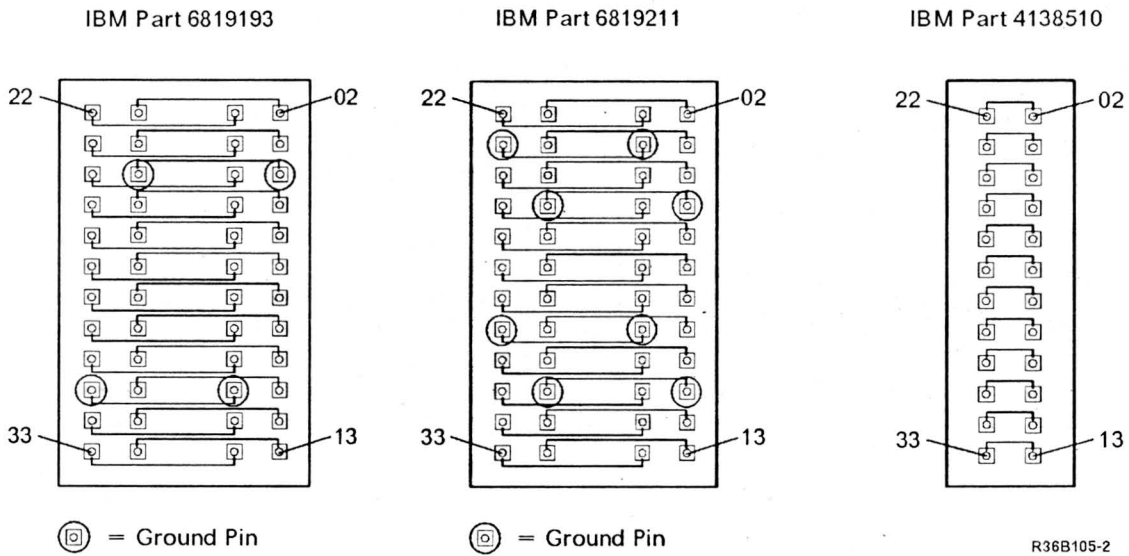

# Top Card Connectors on a 5363 II or IV

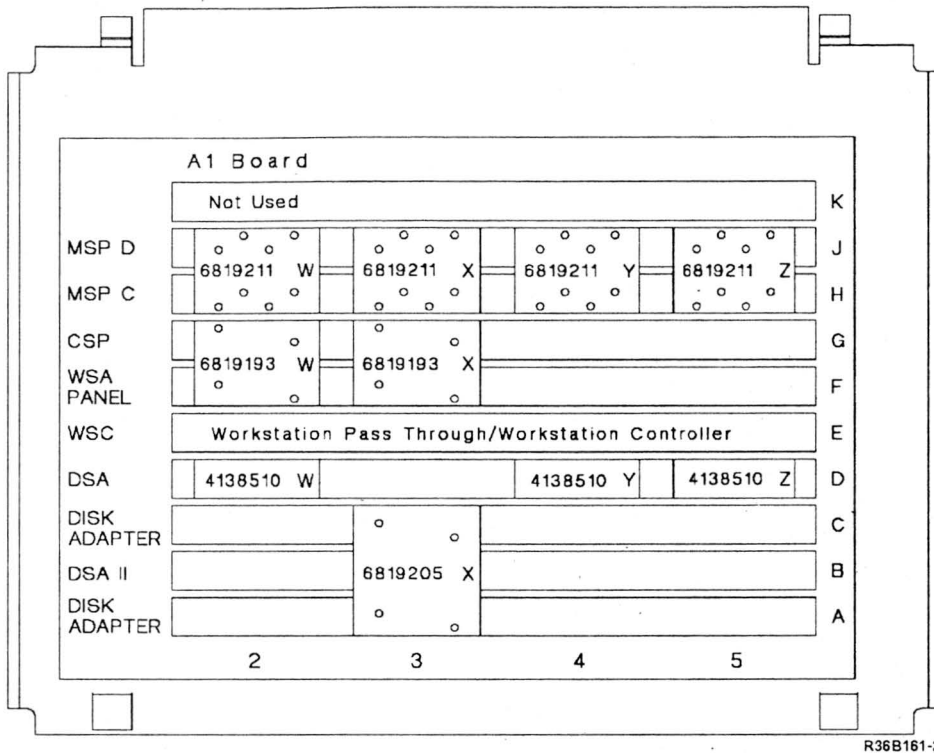

## Top View with Cover Removed

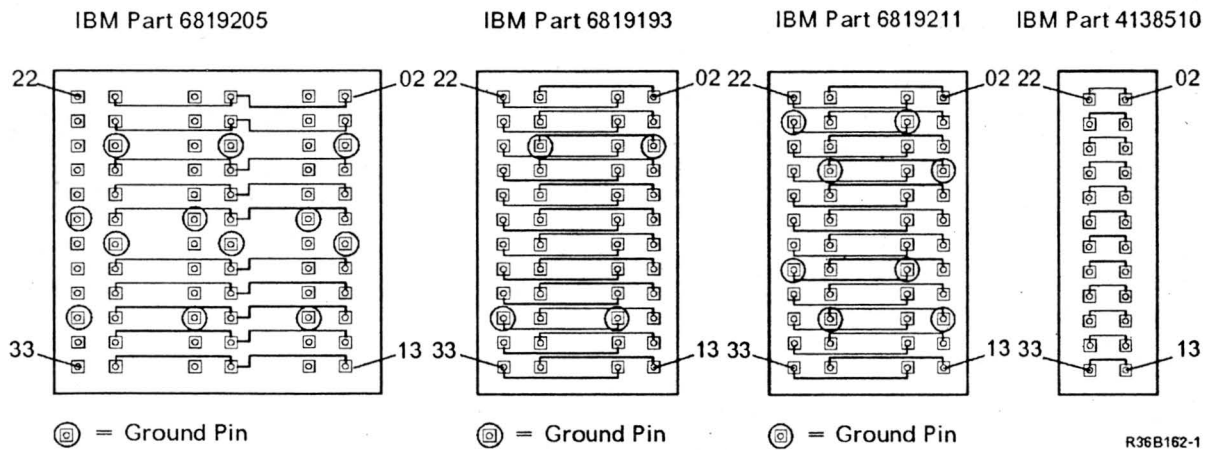

## B1 Board (Feature Machines)

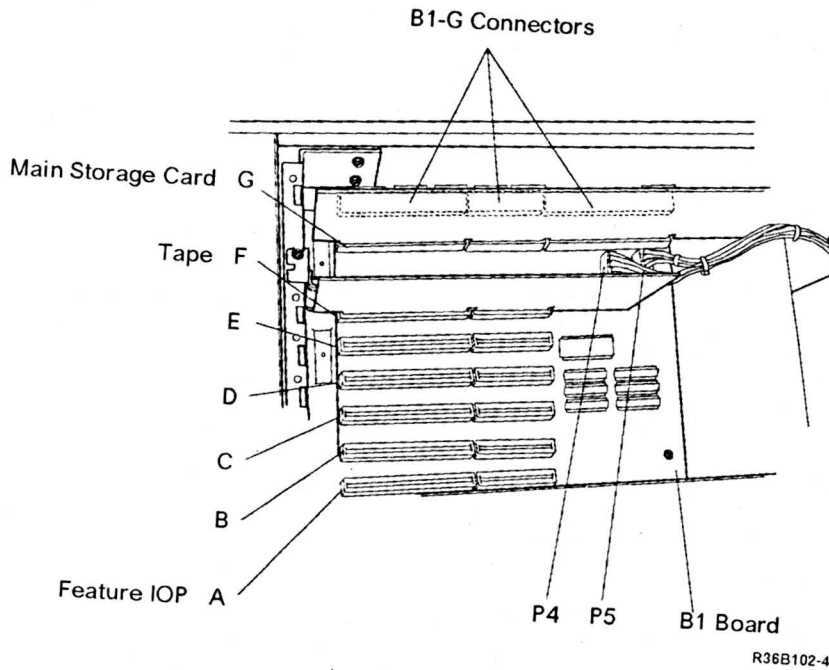

**Note:** The Feature IOP (B1-A) and Main Storage Card (B1-G) must be plugged as shown. Also it is recommended that the Tape feature card be located in position (B1-F) for cable retention purposes. The other cards can be plugged in any remaining slots.

## Card Locations

### A1 System Board

Card	Assembly Part Number	Description
A1K2		Not Used
A1J2	92X3291	MSP Data Flow
A1H2	92X3292	MSP Control
A1G2	92X3293	CSP
A1F2	92X3221	Work station adapter/control panel interface (5363, 5363 I, and 5363 III)
A1F2	92X7255	Work station adapter/control panel interface (5363 II and IV)
A1E2	92X3296	Work station controller
A1E2	92X3295	Pass through
A1D2	92X3294	Data storage adapter card
A1C2	92X3224	Disk adapter
A1C2	92X7256	Disk adapter (5363 II, III, and IV) <sup>1</sup>
A1B2	92X6495	Data storage adapter card (5363 II and IV)
A1A2	92X7256	Disk adapter (5363 II and IV) <sup>1</sup>

### B1 Feature Board

Card	Assembly Part Number	Description
B1-G	92X3222	Main storage card (1-MB)
B1-G	21F4225	Main storage card (1-MB) (5363 III and IV)
B1-G	92X7231	Main storage card (2-MB)
B1-G	21F4226	Main storage card (2-MB) (5363 III and IV)
B1-F	92X7353	53 Mb Tape
B1-F	92X7443	120 Mb Tape
	8286098	BSC
	60X8192	IBM Realtime Interface Co-Processor
	58X7285	RS232 Interface Card
	58X7287	V.35 Interface Card
	83X9147	LAN
	8286099	SDLC
	8286147	ASYNC
B1-A	92X7359	Feature IOP (Input Output Processor)

<sup>1</sup> These cards are interchangeable.

---

## Section 3. General Procedures

- 305 Cover Removal 3-2
- 310 Logic Card Fan Removal and Replacement Procedures 3-5
- 312 Performing a System Reset 3-7
- 314 Starting the CSP 3-7
- 316 Performing a System Dump 3-7
- 320 Loading the SSP 3-8
- 321 Auto Configuring the System 3-8
- 322 Reloading the SSP Diskettes 3-9
- 324 Reloading the System Microcode Without Auto Configure 3-9
- 326 Load Options for SSP, Reload, and Customize 3-10
- 328 Service Procedures under SSP 3-11
- 329 Summary of Useful SSP Procedures 3-12
- 330 Loading the DCP from Disk 3-14
- 332 Loading the DCP from Diskette 3-14
- 336 Load Options for DCP 3-15
- 338 Diagnostic Tests under DCP 3-16
- 340 B1 Board Removal and Replacement Procedures 3-17
- 342 A1 Board Removal and Replacement Procedures 3-19
- 350 Alter or Display Storage 3-23
- 360 Getting ERAP Reports 3-25

---

## 305 Cover Removal

### To Remove the Covers

1. Power off the 5363.
2. Pull on the bottom of the rear cover to loosen.

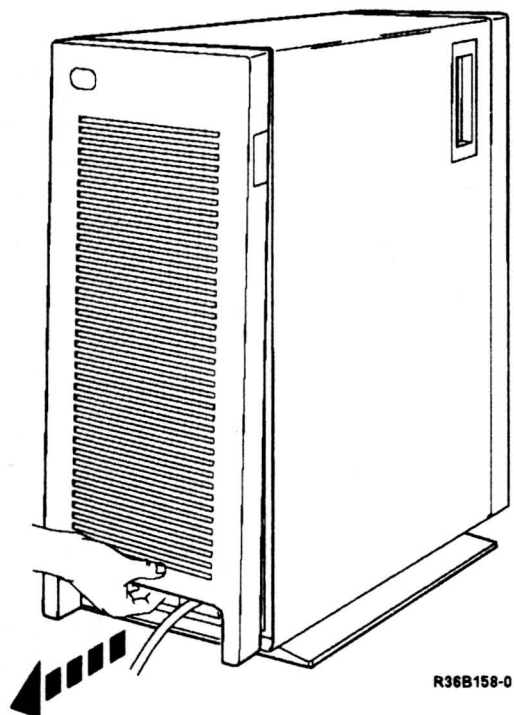

R36B158-0

3. Pull on the sides of the rear cover to remove.

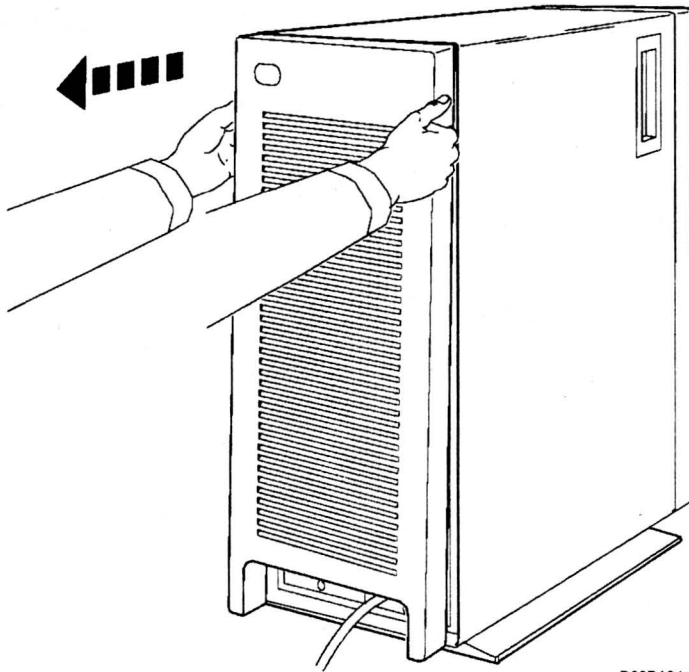

R36B104-2

4. Remove the two screws holding the unit cover at the upper rear area of the frame.

5. Remove the 5363 System Unit cover by sliding it from the rear to the front. You might find it necessary to tilt the cover up to remove it from the frame.

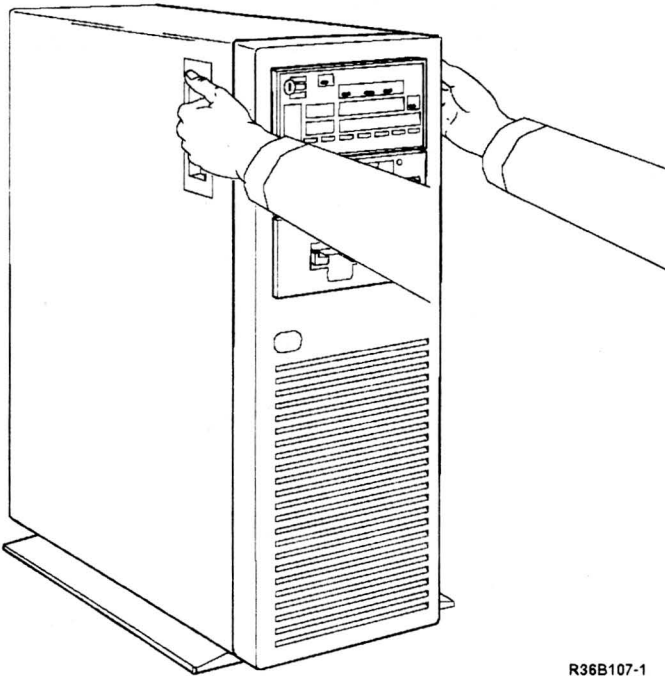

R36B107-1

6. Reinstall the covers by performing the above steps in reverse order.

**Note:** When you reinstall the 5363 System Unit cover, press down to ensure that it makes good contact with the base frame.

## 310 Logic Card Fan Removal and Replacement Procedures

### To remove the fan:

1. Power off the 5363 and disconnect the power cord at the customer power outlet and the 5363.
2. Remove the covers ("305 Cover Removal" on page 3-2).
3. Remove the fan airflow cover.
4. Support the fan and remove the 4 screws.
5. Slide the fan out of the 5363 frame.
6. Disconnect the fan power connector.

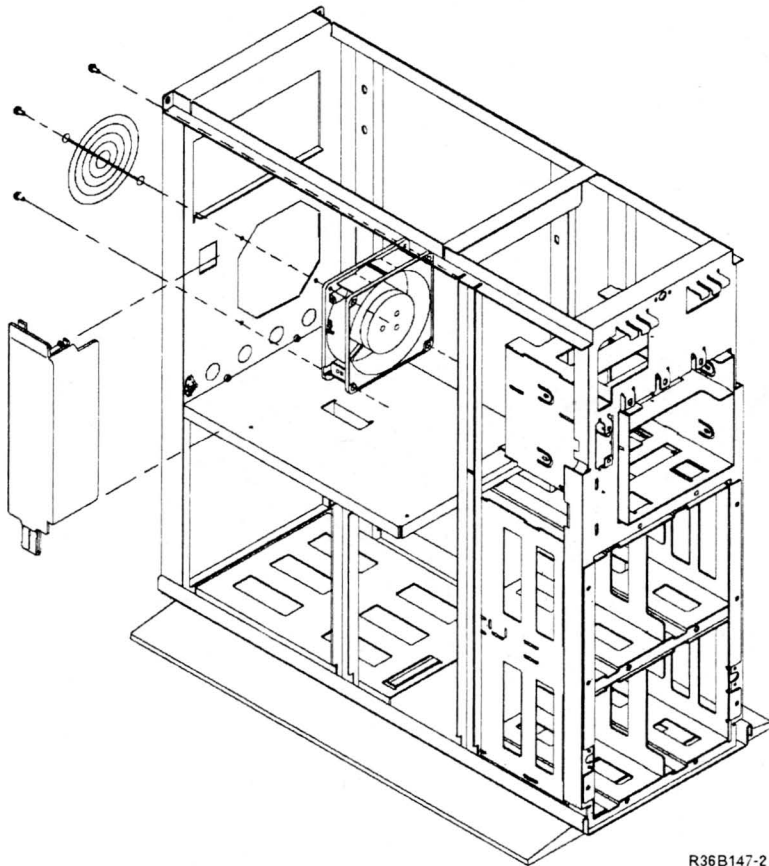

R36B147-2

**Note:** The arrows on the fan indicate air flow direction. The horizontal arrow points to the rear of the machine.

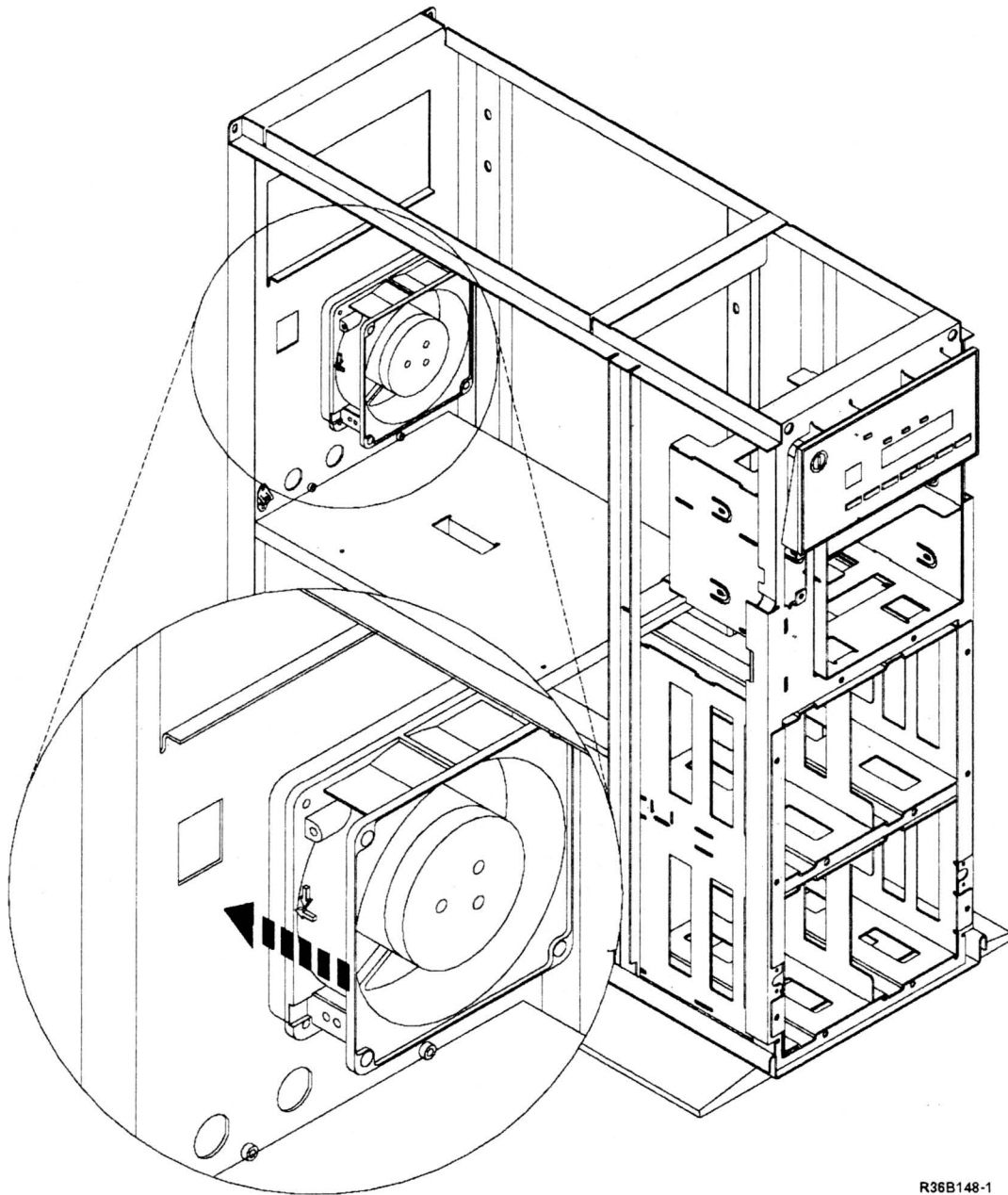

R36B148-1

7. Reinstall the fan by performing the above steps in reverse order.

---

## **312 Performing a System Reset**

The system is normally reset during a power-on or IPL operation. To cause a system reset:

1. Set the Security switch to Service.
2. Select function 5 (System Reset).
3. Press the Start Function key.

---

## **314 Starting the CSP**

1. Set the Security switch to Service.
2. Select function 9 (Start CSP).
3. Press the Start Function key.

---

## **316 Performing a System Dump**

1. Set the Security switch to Service.
2. Select function 4 (Dump).
3. Press the Start Function key.
4. Follow the prompts.

The system is reset and the CSP is started. If SSP was running before this function was selected, a system dump occurs.

---

## 320 Loading the SSP

The SSP is normally loaded at the time the system is powered on. Function 1 (IPL) permits the customer or service representative to load the SSP at a later time without powering the system off and on again.

The Security switch determines the method of loading the SSP.

### Security Switch – Normal Position

1. Select function 1 (IPL). The 4-character display is blank.
2. Press the Start Function key. The IPL Sign On prompt is displayed after IPL testing is complete see Notes 1, 2, and 3.

### Security Switch – Service Position

1. Select function 1 (IPL).

The 4-character display contains 0000. If the Start Function key is pressed now, a normal customer IPL will occur.

To bypass the wrap tests, alter the 4-character display to FF00.

2. Press the Start Function key. The IPL Sign On prompt is displayed after IPL testing is complete see Notes 1, 2, and 3.

#### Notes:

1. See “326 Load Options for SSP, Reload, and Customize” on page 3-10 for approximate IPL times.
2. See “328 Service Procedures under SSP” on page 3-11 for available tests under SSP.
3. See “329 Summary of Useful SSP Procedures” on page 3-12 for a summary of useful SSP procedures.

---

## 321 Auto Configuring the System

1. Ensure that the Security switch is in the Service position.
2. Insert diskette 61.
3. Select function 3 (IPL Diagnostic Diskette).

The 4-character display contains 0000. To perform a normal customer auto configuration, alter the 4-character display to 1000. To perform a service representative auto configuration, alter the 4-character display to CECE. See “326 Load Options for SSP, Reload, and Customize” on page 3-10.

4. Press the Start Function key. Follow the displayed instructions to auto configure and customize the system.

---

## 322 Reloading the SSP Diskettes

**Note:** Reloading the SSP diskettes is a customer task.

1. Ensure that the Security switch is in the Service position.
2. Insert the first backup diskette, tape, or SSP diskette (SSP01).
3. Select function 2 (Reload).

The 4-character display contains 0000. If the Start Function key is pressed now, a normal reload of the SSP diskettes will occur. To bypass the wrap tests, alter the 4-character display to FF00.

4. Press the Start Function key. Follow the displayed instructions to load the SSP diskettes to disk.
5. Inform the customer that he or she can now reload the program products/utilities beginning with task 2 in the manual *Performing the First System Configuration for Your System*—5363, SC21-9686.

---

## 324 Reloading the System Microcode Without Auto Configure

1. Ensure that the Security switch is in the Service position.
2. Insert the diagnostic diskette (diskette 61).
3. Select function 3 (IPL Diagnostic Diskette).

The 4-character display contains 0000. If the Start Function key is pressed now, a normal diskette IPL will occur. To bypass the wrap tests, alter the 4-character display to FF00.

4. Press the Start Function key. The DCP Main menu is displayed.
5. Select the System Customize option from the DCP Main menu.

**Note:** System customize destroys all microcode patches (including free-lance patches) on the disk. If these patches are needed, you must apply them again.

6. Follow the prompts.
7. When this procedure is completed, and you were sent here from "Procedure 121" on page 1-8, return to procedure "Disk Drive Reload" on page 1-8.

**Note:** If Auto Configure is required, see "321 Auto Configuring the System" on page 3-8.

## 326 Load Options for SSP, Reload, and Customize

Select Function	Load Option	Load From	Program Loaded	IPL Time <sup>1</sup>	Description
1	0000	Disk	SSP	5-9	Normal load.
1	FF00	Disk	SSP	4	Bypass wrap tests.
2	0000	Diskette (SSP01)	SSP Reload	4-12	Load main storage SSP from diskette and reload SSP diskettes to disk.
2	FF00	Diskette (SSP01)	SSP Reload	1-5	Load main storage SSP from diskette, bypass wrap tests, and reload SSP diskettes to disk.
3	0000 <sup>3</sup>	Diskette 61	DCP	4-8	Sense devices, assemble UDT and run I/O wraps.
3	1000	Diskette 61	AUTO CONFIG	4-8	Sense devices, assemble UDT and run I/O wraps. Prompts user for input about the system.
3	10FF	Diskette 61	AUTO CONFIG	4-8	Sense devices, assemble UDT and bypass wrap tests. Prompts user for input about the system.
3	CECE <sup>2</sup>	Diskette 61	AUTO CONFIG	4-8	Sense devices, assemble UDT and run I/O wraps. Prompts user for input about the system.
3	FF00 <sup>3</sup>	Diskette 61	DCP	1-2	Bypass wrap tests; sense devices, assemble UDT.
3	FFF0 <sup>3</sup>	Diskette 61	DCP	1	Load DCP from diskette, bypass channel wraps.
3	2222 <sup>4</sup>	Diskette 61	INIT	4-8	Initialize the disk, run wraps.
3	22FF <sup>4</sup>	Diskette 61	INIT	2-6	Initialize the disk, bypass wraps.

<sup>1</sup> IPL times are approximate in minutes.

<sup>2</sup> The CECE load option displays the hardware configuration. You can select an option to change the machine serial number or to change the printer address. After you select the option, follow the prompts to completion.

<sup>3</sup> The DCP Main menu appears and the following options are available: System Customize (insert diskette 62), Program Patch (insert diskette 62), System Records List (insert diskette 62), Network Analysis (insert diskette 61), RPQ Utilities, Supervisor Options and Change System Printer. After you select the option, follow the prompts to completion.

<sup>4</sup> Select the disk drive to be initialized and wait until it is done initializing. When disk initialization is completed, the screen will state that the disk is 100% initialized. You may then perform an AUTO CONFIG.

---

## 328 Service Procedures under SSP

**Note:** To load SSP, see "320 Loading the SSP" on page 3-8.

Enter one of the following SSP procedures on the command line:

- SYSTEST (system test):
  - Disk exerciser
  - Diskette exerciser
  - Display station exerciser
  - Main storage processor exerciser
  - Printer exerciser
  - Communications exerciser
  - Tape exerciser
  - Local area network
- COMMTEST (communications diagnostic tests):
  - Basic communications diagnostic test
  - Additional communications diagnostic tests
    - IBM LPDA local and remote modem diagnostic tests
    - Remote loop back wrap tests
- STATEST (SDLC station test)
- BSCTEST (BSC online test)
- SDLCTEST (SDLC online test)
- ERAP (error recording analysis program):
  - System summary
  - Elapsed time counters
  - Reports for all devices
  - Single reports by device
- TESTREQ (test request):
  - Display verification
  - Work station printer verification
  - Configuration data
  - ERAP (reports associated with work stations)
- PROBLEM (problem determination):
  - Diskette
  - Local work station
  - Communications
  - Tape
  - Local area network

## 329 Summary of Useful SSP Procedures

The following table describes useful SSP procedures. See the *System Reference* manual and the *Program Problem Diagnosis and Diagnostic Aids* manual for more information.

Key in This SSP Name	Press This Key	Description or Action
ALTERCOM	Help	Gives the prompt to change some communications parameters. (For the display station only). See "930 Displaying Communications Configuration Status" on page 9-5.
APAR	Help	Gives the prompt to create APAR diskettes or to copy diagnostic information to disk or diskette.
BSCTEST	Enter	Gives the prompt to perform the BSC on-line tests.
BUILD	Enter	Displays the data on disk after a disk error with the option to correct data.
COMMTEST	Enter	Shows the menu with options to perform the communications diagnostic tests.
COPYII	Help	Gives the prompt to copy files from a diskette to one or more other diskettes with the same format. (Not for diagnostic diskettes)
D C OR STATUS COMM	Enter	Displays the communications configuration data set by the ALTERCOM procedure.
D H OR STATUS COMCNFIG	Enter	Displays the communications configuration data set by the SETCOMM procedure.
DFA	Help	Gives the prompt to print or display the selected system data areas from disk or from a diskette made by the APAR procedure.
DIAGCOPY	Enter	Copies files from any diagnostic diskette to one or more other diagnostic diskettes with the same format.
DIAGINIT	Enter	Initializes a diagnostic diskette.
DUMP	Help	Gives the prompt to select and print or display information from the dump file.
ERAP	Enter	Shows the menu with options to display or print the error log reports.
HISTCRT	Enter	Displays entries from the system history file.
HISTORY	Enter	Gives the prompt to display or print selected entries from the system history file.
ICFDEBUG	Help	Runs the SSP-ICF debug program.
ICVERIFY	Help	Gives the prompt to verify that an SSP-ICF subsystem is installed correctly.
INIT	Help	Gives the prompt to initialize a diskette. (Not for diagnostic diskettes)
OFF	Enter	Signs off the user.
PATCH	Enter	Shows the menu with options to patch selected disk or diskette sectors.

<b>Key in This SSP Name</b>	<b>Press This Key</b>	<b>Description or Action</b>
POWER OFF	Enter	Closes files and terminates SSP. (Does not power off the system.)
PROBLEM	Enter	Gives instructions to perform on-line problem determination.
PTF	Help	Gives the prompt to install or remove PTFs (program temporary fixes) or MPTFs (microcode program temporary fixes) to disk.
SDLCTEST	Enter	Gives the prompt to select options from menus to perform the SDLC on-line tests.
SERVICE	Help	Shows the menu with options to run service aid procedures.
SERVLOG	Help	Gives the prompt to add entries to the system service log.
SETCOMM	Help	Gives the prompt to change some communications parameters. See "930 Displaying Communications Configuration Status" on page 9-5.
SETDUMP	Help	Gives the prompt to set the address compare dump values for programs running in main storage.
SMF	Help	Shows the menu to select options from menus to measure system actions.
SMFPRINT	Help	Gives the prompt to print a formatted report of the data collected by the system measurement program.
SMFSTART	Help	Gives the prompt to start the system measurement program.
SMFSTOP	Enter	Stops the system measurement program.
START	Help	Shows a menu that lets jobs run, start, or print. The option to start system service authorization lets you specify a display station to be used to enter any procedure or command to service the system.
STATEST	Enter	Gives the prompt to select options from menus to perform the remote work station tests.
STOP	Help	Shows a menu that prevents jobs from running, starting, or printing. The option to start system service authorization lets you return a display station to its normal use.
SYSTEST	Enter	Shows the menu to select exercisers to perform diagnostic testing of the system. No customer jobs can be running.
TAPEINIT	Help	Shows the menu with options to create the label on the tape volume.
TAPESTAT	Enter	Gives the prompt to display or print the selected system data for the tape volumes.
TESTDSKT	Help	Shows the menu with options to perform tests on the diskette drive and media.
TESTREQ	Enter	Shows the menu with options to perform the local and remote work station verification tests.
TRACE	Help	Gives the prompt to keep a record of selected events on the system.
VARY	Help	Gives the prompt to change the status of a display station, a printer, the system printer, or the diskette drive to on-line or off-line.

---

### **330 Loading the DCP from Disk**

1. Ensure that the Security switch is in the Service position.
2. Select function 2 (Reload).

The 4-character display contains 0000. If the Start Function key is pressed now, a normal SSP reload will occur. To load the system for dedicated service, alter the 4-character display to F800 (bypass wraps) or F801 (run wraps).

3. Press the Start Function key. The DCP Main menu is displayed after IPL is complete see Notes 1 and 2.

#### **Notes:**

1. See "336 Load Options for DCP" on page 3-15 for approximate IPL times.
2. See "338 Diagnostic Tests under DCP" on page 3-16 for available tests.

---

### **332 Loading the DCP from Diskette**

1. Ensure that the Security switch is in the Service position.
2. Insert the diagnostic diskette 61, in the diskette drive.
3. Select function 3 (IPL Diagnostic Diskette).

The 4-character display contains 0000. If the Start Function key is pressed now, a normal diagnostic IPL will occur. To bypass the wrap tests, alter the 4-character display to FF00.

4. Press the Start Function key. The DCP Main menu is displayed after IPL is complete see Notes 1 and 2.

#### **Notes:**

1. See "336 Load Options for DCP" on page 3-15 for approximate IPL times.
2. See "338 Diagnostic Tests under DCP" on page 3-16 for available tests.

## 336 Load Options for DCP

Select Function	IPL Option	IPL From	Program Loaded	IPL Time <sup>1</sup>	Description
2	F800 <sup>3</sup>	Disk	DCP	2-6	Load DCP from disk, bypass wrap tests.
2	F801 <sup>3</sup>	Disk	DCP	2-8	Load DCP from disk, run wraps.
2	F8F0 <sup>3</sup>	Disk	DCP	2-5	Load DCP from disk, no disk motor start or wrap.
3	FA03	Diskette 61	DCP	No IPL	Use only when directed. See "160 Isolating Main Storage Problems" on page 1-13. Stop at the end of MSP tests to allow changing of control panel input.
3	FC03	Diskette 61	DCP	No IPL	Use only when directed. See "Procedure 123" on page 1-10. Loop on MSP tests and allow no unsatisfactory 2K blocks of main store.
3	FF00 <sup>3</sup>	Diskette 61	DCP	1-2	Bypass wrap tests; sense devices, assemble UDT.
3	FFF0 <sup>3</sup>	Diskette 61	DCP	1	Load DCP from diskette, bypass channel wraps.
3	0000 <sup>3</sup>	Diskette 61	DCP	4-8	Sense devices, assemble UDT and run I/O wraps.
3	2222 <sup>4</sup>	Diskette 61	INIT	4-8	Initialize the disk, run wraps
3	22FF <sup>4</sup>	Diskette 61	INIT	2-6	Initialize the disk, bypass wraps

<sup>1</sup> IPL times are approximate in minutes.

<sup>2</sup> The CECE load option displays the hardware configuration. You can select an option to change the machine serial number or to change the printer address. After you select the option, follow the prompts to completion.

<sup>3</sup> The DCP Main menu appears and the following options are available: System Customize (insert diskette 62), Program Patch (insert diskette 62), System Records List (insert diskette 62), Network Analysis (insert diskette 61), RPQ Utilities, Supervisor Options and Change System Printer. After you select the option, follow the prompts to completion.

<sup>4</sup> Select the disk drive to be initialized and wait until it is done initializing. When disk initialization is completed, the screen will state that the disk is 100% initialized. You may then perform an AUTO CONFIG.

---

## 338 Diagnostic Tests under DCP

**Note:** To load DCP, see "330 Loading the DCP from Disk" on page 3-14 or "332 Loading the DCP from Diskette" on page 3-14.

Select one of the following options from the DCP Main menu:

- Disk Analyze
  - Analyze disk drives
  - Change disk options
  - Display disk report
  - Read a single sector
  - Alternate sector assignment
- System customize
- Program patch
  - Disk patch only
  - Disk (and diskette) patch
  - Free-lance disk patch
- System records list
  - Control storage directory (on disk)
  - Diskette directory (on diskette)
  - EC level table (on diskette)
  - Patch table (on disk or diskette)
  - Prerequisite list (on disk or diskette)
  - Microcode level table (on disk or diskette)
- Network analysis (for local work stations)
- RPQ utilities
- Supervisor options:
  - Printed output to printer (default)
  - Printed output to console
  - Diagnostics from disk
  - Diagnostics from diskette (default)
- Change system printer (to change DCP printer address from default of 30 for the present session only)

**Note:** To change the printer address permanently, use the CECE IPL option. See "326 Load Options for SSP, Reload, and Customize" on page 3-10.

## 340 B1 Board Removal and Replacement Procedures

### To remove the B1 board:

**Note:** Label all cards as to which location they were removed from. This will be of help to you when you reinstall the cards.

1. Power off the 5363 and disconnect the power cord at the customer power outlet and the 5363.
2. Remove the covers ("305 Cover Removal" on page 3-2).
3. Remove all cards plugged into the B1 board.
4. Remove power connectors P4 and P5.
5. Remove the two screws securing the board to the logic board gate.

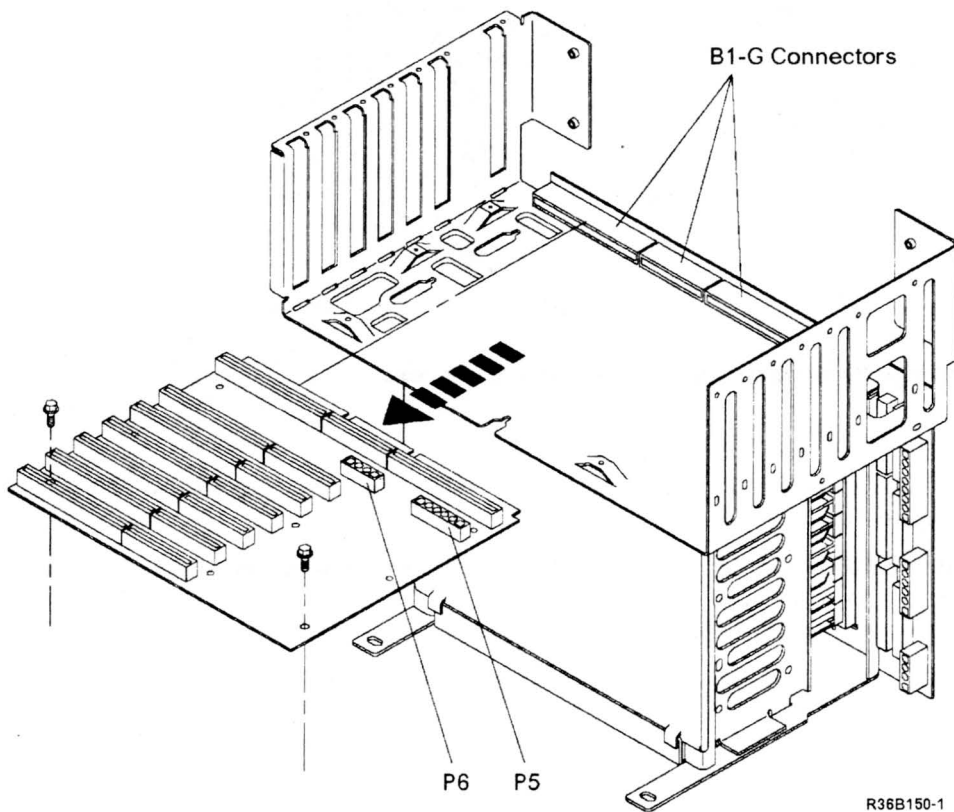

6. Pull and slide the B1 board out of the A1 board connectors B1-G.

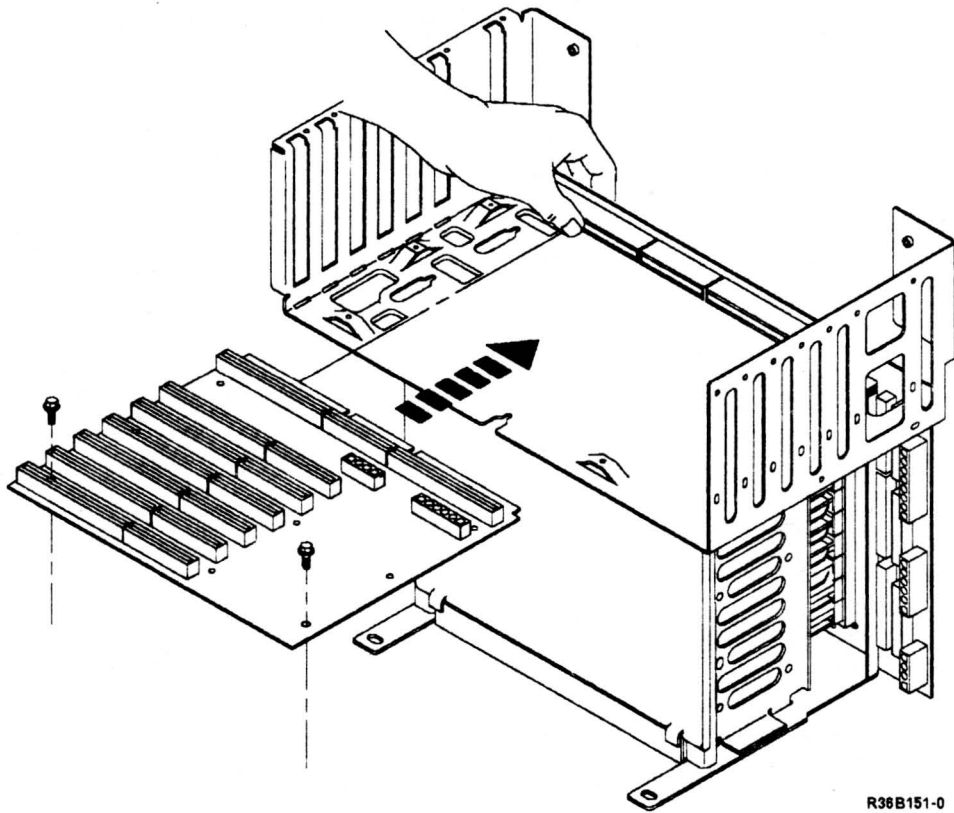

R38B151-0

7. Reinstall the B1 board by performing the previous steps in reverse order.

**Notes:**

1. When reinstalling the B1 board, be sure to engage plastic standoffs on the bottom of the board into the slots on the logic board gate frame.
2. When reinstalling the B1 board, be sure to support the A1 board with one hand as you push the B1 board into the A1 board connectors B1-G.

---

## 342 A1 Board Removal and Replacement Procedures

### To remove the A1 board:

1. Power off the 5363 and disconnect the power cord at the customer power outlet and the 5363.
2. Remove the covers ("305 Cover Removal" on page 3-2).
3. Remove all top card connectors from the cards on the A1 board.  
**Note:** Label all cards as to which location they were removed from. This will be of help to you when you reinstall the cards.
4. Remove and label all cards from the A1 and B1 boards.
5. Remove all power cables from the A1 and B1 boards.
6. Remove all signal cables from the A1 board.
7. Remove the logic card gate fan ("310 Logic Card Fan Removal and Replacement Procedures" on page 3-5).
8. Disconnect the manufacturing test connector.
9. Disconnect the twinaxial connector.
10. Remove the B1 board ("340 B1 Board Removal and Replacement Procedures" on page 3-17, step 5).
11. Remove the six screws from the A1 board frame.

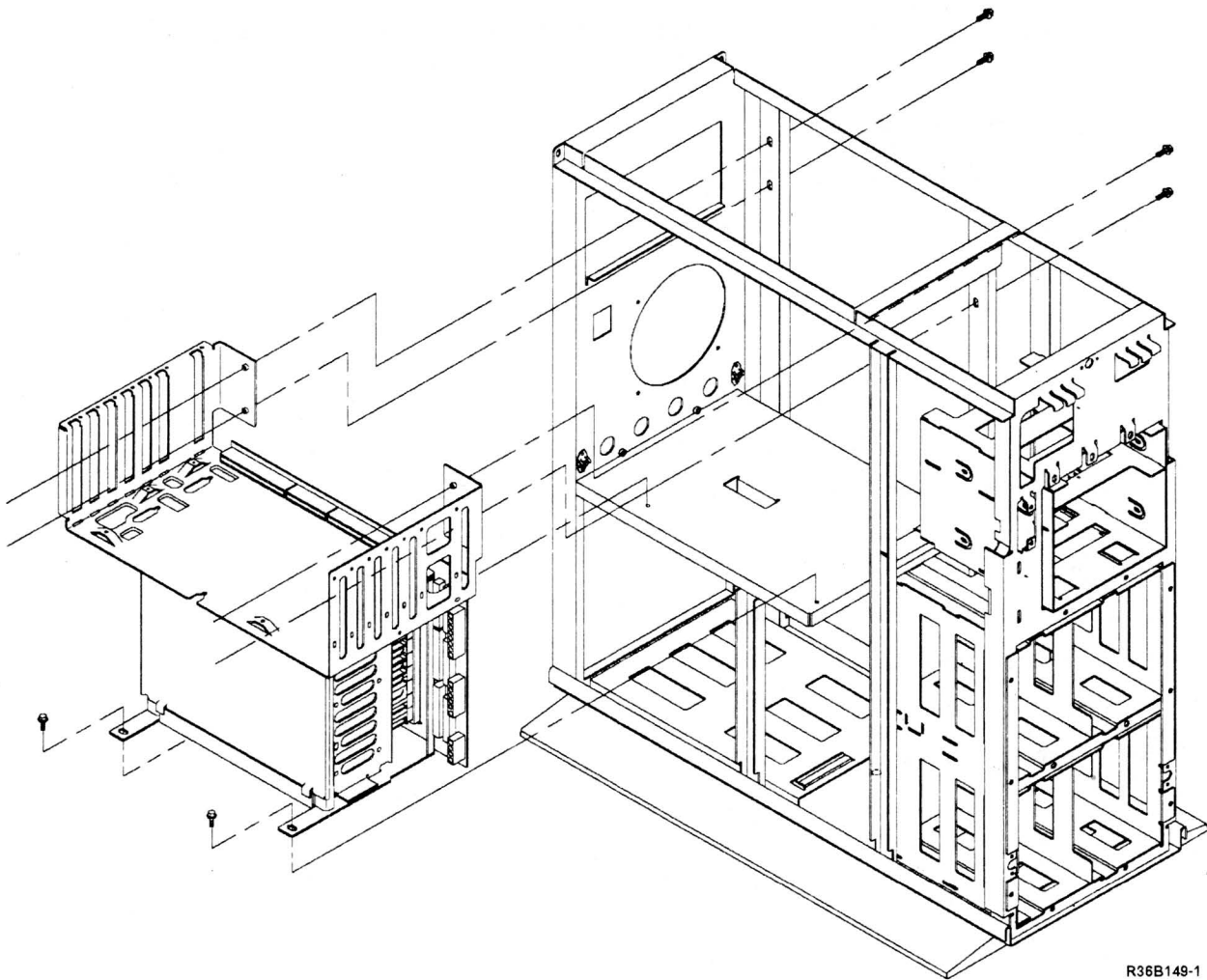

R36B149-1

12. Slide the A1 board logic gate assembly towards you out of the 5363 frame.
13. Place the logic gate on a firm surface with the 12 screws securing the A1 board facing up.  
**Note:** Note the location of the B1-G connectors, this will be of help to you when you reinstall the A1 board. If this note is not followed you may reinstall the A1 board backwards.
14. Remove the 12 screws securing the A1 board to the logic gate assembly.
15. Do not remove the plastic insulator under the A1 board.
16. Remove the plastic standoffs from the old A1 board and reinstall them in the new A1 Board.

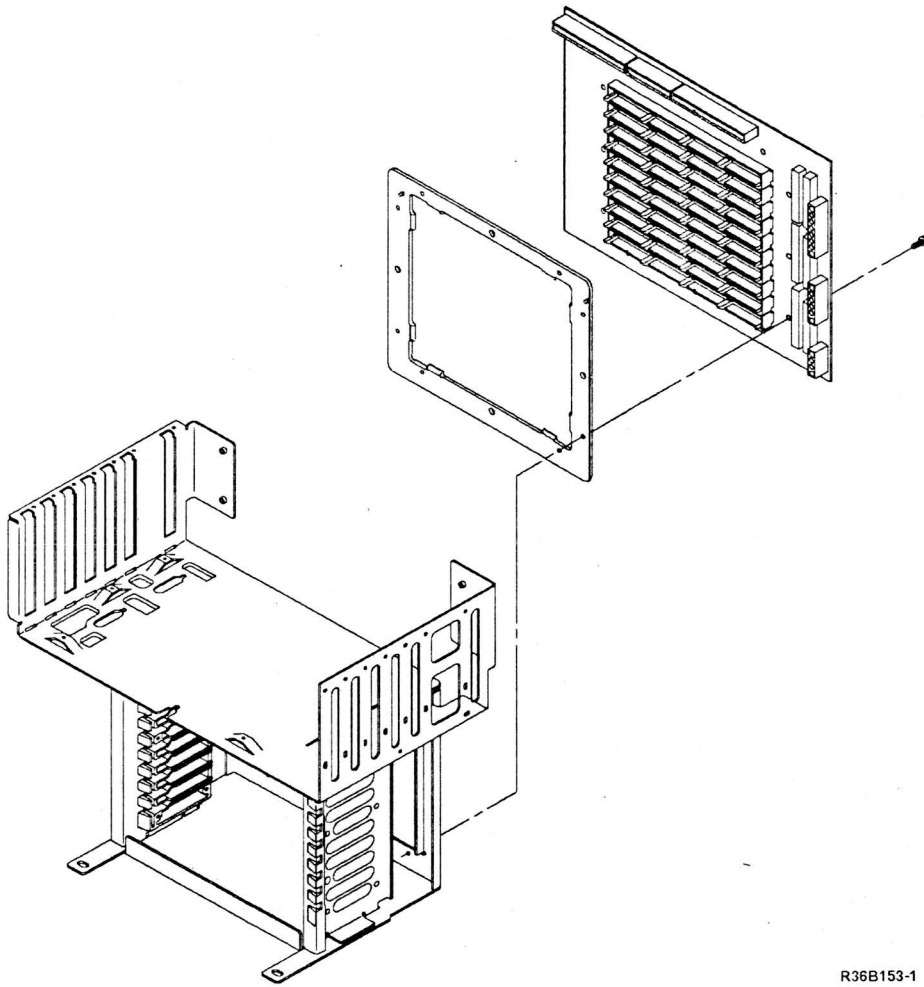

R36B153-1

**Note:** Before installing a new A1 board, check the switch settings. See the following diagram.

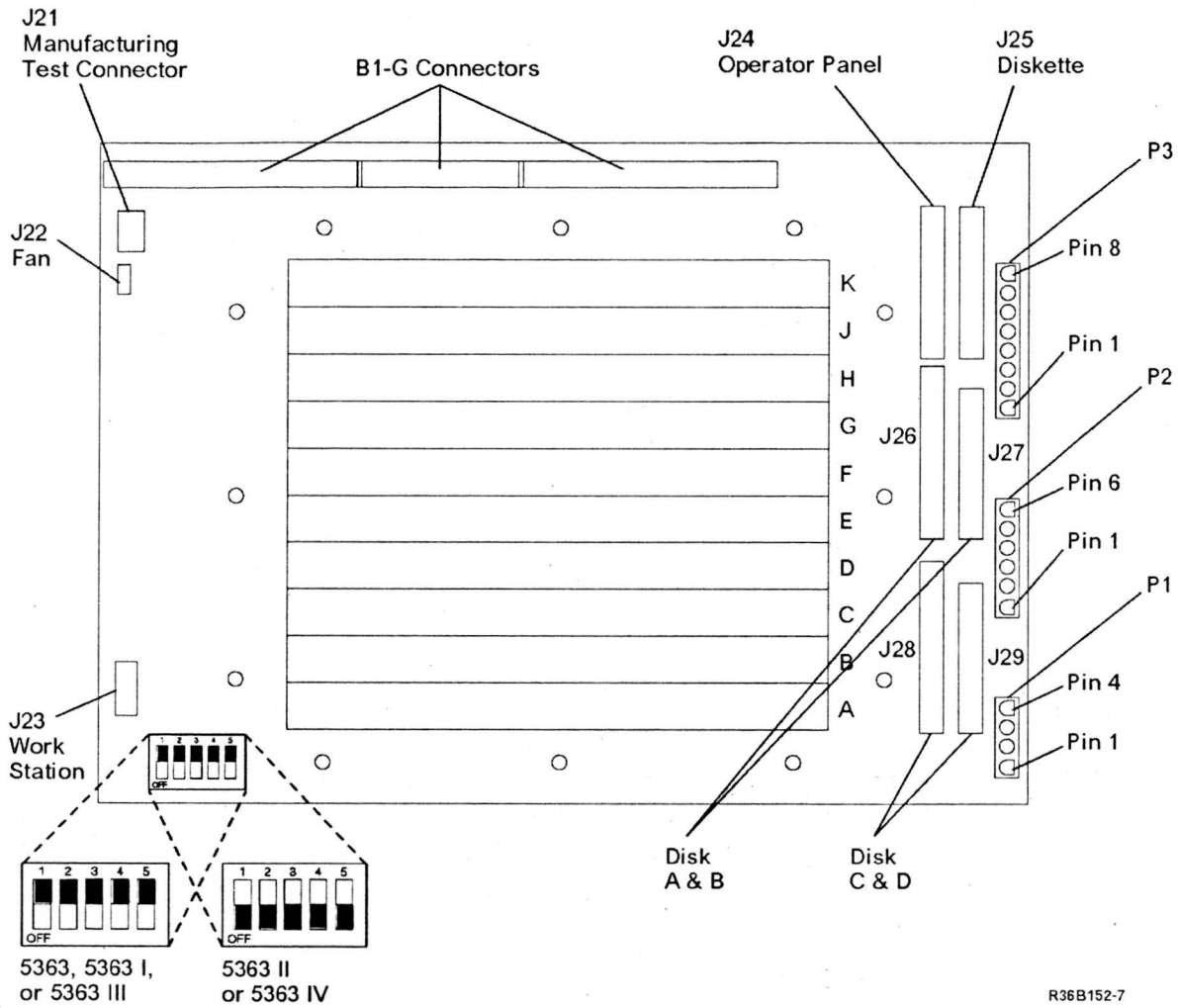

R36B152-7

**Note:** The switches in the lower left corner of the above figure are set at the factory. Check to be sure the switches are set as shown. The dark area indicates where the switch is pushed down.

17. Reinstall the A1 board by performing the previous steps in reverse order.

---

## 350 Alter or Display Storage

The alter/display utility is a dedicated utility that interrupts normal system operation to let you perform specific storage operations. For example, you can alter or display:

- Storage, including:
  - Real main storage
  - Translated main storage
  - Control storage
- Disk storage
- I/O controller storage (display only)
- MSP registers

**Note:** All communication tasks should be completed or stopped before you start the alter/display utility.

You can determine if a communications line is active by inspecting the Communications Line Status lights for each line (“935 Displaying Communications Line Status” on page 9-6). The DTR (data terminal ready) light is on when the line is active.

**Note:** If the spool writer is allocated to the system printer, the alter/display utility print options will not print. The spool writer must be stopped before you can allocate the system printer to the alter/display utility. All alter/display screens can be printed on the system printer, using the Print key.

Selecting function 7 to start the alter/display utility stops the main storage processor (MSP). However, the Alter/Display menu does not appear on the system console when the terminal unit block (TUB) chain is locked or if a work station error is being processed. If the Alter/Display menu does not appear on the system console, end the alter/display function and attempt to start the alter/display utility again.

If the Alter/Display Option menu still does not appear, it is probably because some program has the TUB chain locked. End the alter/display function and wait until a later time to start the alter/display utility.

### To Start the Alter/Display Function

1. Ensure that the Security switch is in the Service position.
2. Select Function 7 (Console Alter/Display) and press the Start Function key.  
The Alter/Display menu is displayed on the system console.
3. Select an alter/display option and follow the displayed instructions.

## To End the Alter/Display Option

There are two methods of ending the alter/display options. (For options 10 and 12, use only method 1.)

### Method 1: Using the Cmd7 Key

On all displays except the Alter/Display Options menu, you can use the Cmd7 key to end the alter/display option. For the Alter/Display Options menu, see the procedure ("To End the Alter/Display Function").

### Method 2: Using the E Parameter

All alter/display options (except options 10 and 12) display an end (E) parameter. Key an E in the parameter field and press the Enter key; the Alter/Display Options menu is displayed.

**Note:** On storage displays, change the storage indicator (M, R, X, or C) on the first storage address to an E.

## To End the Alter/Display Function

There are two methods of ending the alter/display function. Use method 1 when you can display the Alter/Display Options menu. Use method 2 when you cannot use method 1.

### Method 1: Using the Alter/Display Menu

1. Select option 0 (Exit Alter/Display) from the Alter/Display Options menu.
2. Press the Field Exit key.

### Method 2: Using the Control Panel

1. If the Output Display light is off, press the Display key. A 1 is displayed in the low-order position of the 4-character display; the three high-order positions are blank.
2. Change the 1 to a 0 using the low-order Input key.
3. Press the Start Function key.

**Note:** For more information about using the alter/display utility, see the manual *Program Problem Diagnosis and Diagnostic Aids*, SY21-0593.

---

## 360 Getting ERAP Reports

The error recording analysis procedure (ERAP) gets, formats, and displays or prints error statistical information. There are four methods of getting ERAP reports:

- The ERAP procedure under SSP lets you get system summary reports and detailed device reports from the system error log.
- The test request procedure (TESTREQ) under SSP lets you get ERAP reports associated with work stations and communications devices.
- The Test Request function key of any local or remote work station lets you get ERAP reports associated with work stations and communications devices.
- A system test (SYSTEST) option lets you get system summary reports and detailed device reports from the system error log.

### To Get ERAP Reports under SSP

1. Enter ERAP.
2. Select the type of ERAP report.
3. Select the option to display or print the ERAP report.

### To Get ERAP Reports Using the Test Request Procedure

1. Enter TESTREQ.
2. Select the ERAP option.
3. Select the type of ERAP report.

### To Get ERAP Reports Using the Work Station Test Request Key

This procedure assumes that you have a sign-on display but have not signed on a work station.

1. Press the Cmd key and the Test Request function key (backspace key).
2. Select the ERAP option.
3. Select the type of ERAP report.

### To Get ERAP Reports When Running the System Test

1. Press the Attn key.
2. Select option 4 (Set Inquiry Condition for Program) from the Inquiry menu.
3. Select the option that starts ERAP.
4. Select the ERAP reports you want.
5. Use the Cmd7 key to return to SYSTEST.

## Example Error History Table

ERROR HISTORY TABLE FOR XXXXXXXX								
FROM: XX/XX/XX XX:XX:XX			TO: XX/XX/XX XX:XX:XX					
DATE	TIME	SRC	(Information used to generate SRCs)					
YY/MM/DD	HH:MM:SS		.....HEX.....					
XX/XX/XX	XX:XX:XX	XXXX	XXXX	XXXX	XXXX	XXXX	XXXX	XXXX
XX/XX/XX	XX:XX:XX	XXXX	XXXX	XXXX	XXXX	XXXX	XXXX	XXXX
XX/XX/XX	XX:XX:XX	XXXX	XXXX	XXXX	XXXX	XXXX	XXXX	XXXX
XX/XX/XX	XX:XX:XX	XXXX	XXXX	XXXX	XXXX	XXXX	XXXX	XXXX

### Notes:

1. When you display ERAP reports for some devices, not all of the information available in the reports is shown. However, the additional information is available when you print or spool the reports (see the procedure "Spool and Display ERAP Reports").
2. See the manual *Program Problem Diagnosis and Diagnostic Aids*, SY21-0593, to interpret special fields associated with communications SRCs.

## Spool and Display ERAP Reports

The local work station attachment and disk error history tables contain additional information that is not displayed. When a printer is busy, or is not available, you can send the ERAP report to the system spool writer. The spooled output can be displayed at a local work station using the following procedures.

### To Spool the ERAP Output

1. From the ERAP Main menu, select the option for disk or local work station.
2. Select a disk drive or the local work station attachment.
3. Select the option to print the report.
4. Enter the ID of the printer to receive the output and the additional output option (S) to spool the output.

**Note:** The printer ID must be valid but the printer does not need to be operational.

5. Enter the desired time range.

**Note:** If the selected printer is not operational, a message is sent to the system console indicating that the printer and the system are not communicating. If this occurs, use option 1 to respond to the message.

6. End ERAP and return to the Main (help) menu.

## To Display the Spooled Output

1. From the Main menu, select the option to perform general system activities.
2. From the SYSSSEN menu, select the option to control printing (spool file).
3. On the Spool File Status display (upper half of the display), locate and record the spool ID (SP-ID) number for the procedure (PROC) ERAP.
4. From the SPOOLJOB menu (lower half of the display), select the option to control the spool writer and stop spooling to the selected printer, or select the option to hold entries and enter the spool ID. Return to the SPOOLJOB menu.
5. From the SPOOLJOB menu, select the option to copy or display entries.
6. On the COPYPRT procedure prompt, enter the spool ID (first item) and CRT (last item).  
**Note:** You can also copy the ERAP data to a named file, and you can cancel or release the spool entry in the same operation.
7. On the display that shows the error history table, position the cursor to the DISP START POS field and enter 70. You are now displaying the last 62 positions of the spooled output. Use the roll keys to view entries in the table.
8. Use the Cmd7 key to return through the prompts and menus. Restart the spool writer, or release or cancel entries as you return.



---

## Section 4. Power Procedures

- 405 Base Power Supply Removal 4-2
- 406 Feature Power Supply Removal 4-3
- 410 Power On/Off Actuator Switch and Cable Check Removal/Replacement Procedure 4-4
- 420 Power Supply FRU Isolation Procedure 4-6
- 425 Power Point-to-Point Overview 4-9
- 430 AC Point-to-Point 4-10
- 435 DC Voltage Distribution 4-11
- 440 Base and Feature DC Voltage Tolerances 4-13
- 445 Maximum Ripple Voltage 4-13

## 405 Base Power Supply Removal

1. Power off the 5363.
2. Disconnect the power cord from the 5363.
3. Disconnect the feature power supply cable if present.
4. Remove the covers ("305 Cover Removal" on page 3-2).
5. Disconnect the power on/off actuator cable, go to "Actuator/Cable Removal/Replacement Procedure" on page 4-4, step 5.
6. Disconnect the power supply connectors to the A-1 board, go to "342 A1 Board Removal and Replacement Procedures" on page 3-19 (P1, P2, and P3), the disk drives (P6 and P7), and to the diskette drive (P8).

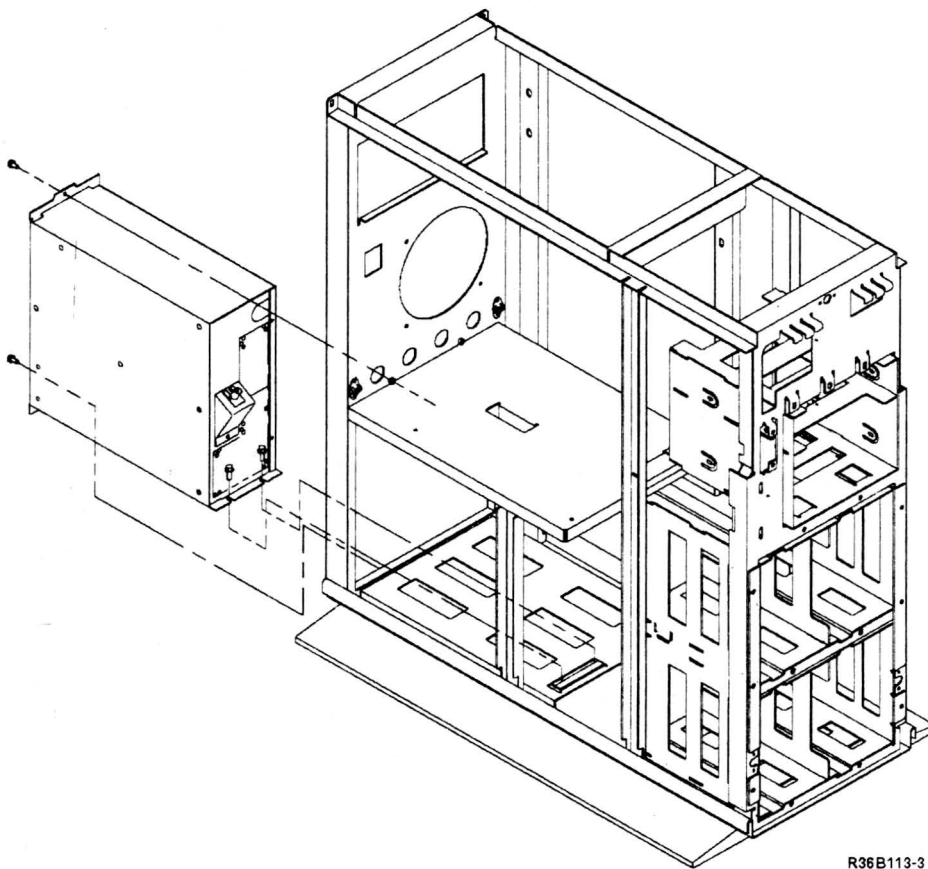

R36B113-3

7. Remove the two screws from the rear of the 5363 that hold the base power supply, and the screws that hold the forward base tab of the power supply to the 5363 frame.
8. Slide the power supply toward the rear of the 5363 to clear the tabs on the frame, and lift upward to remove.
9. Set the line voltage switch to the proper voltage for your 5363.
10. Install the new power supply by performing the previous steps in reverse order. Ensure that you slide the power supply under the tabs on the 5363 frame.

## 406 Feature Power Supply Removal

1. Power off the 5363.
2. Disconnect the power cord from the 5363.
3. Remove the covers ("305 Cover Removal" on page 3-2).
4. Disconnect the power cable connected to the base power supply.
5. Disconnect the power supply connectors to the B1 board (P4, P5), the disk drive C (P9), the disk drive D (P10), and to the tape drive (P11), if installed.

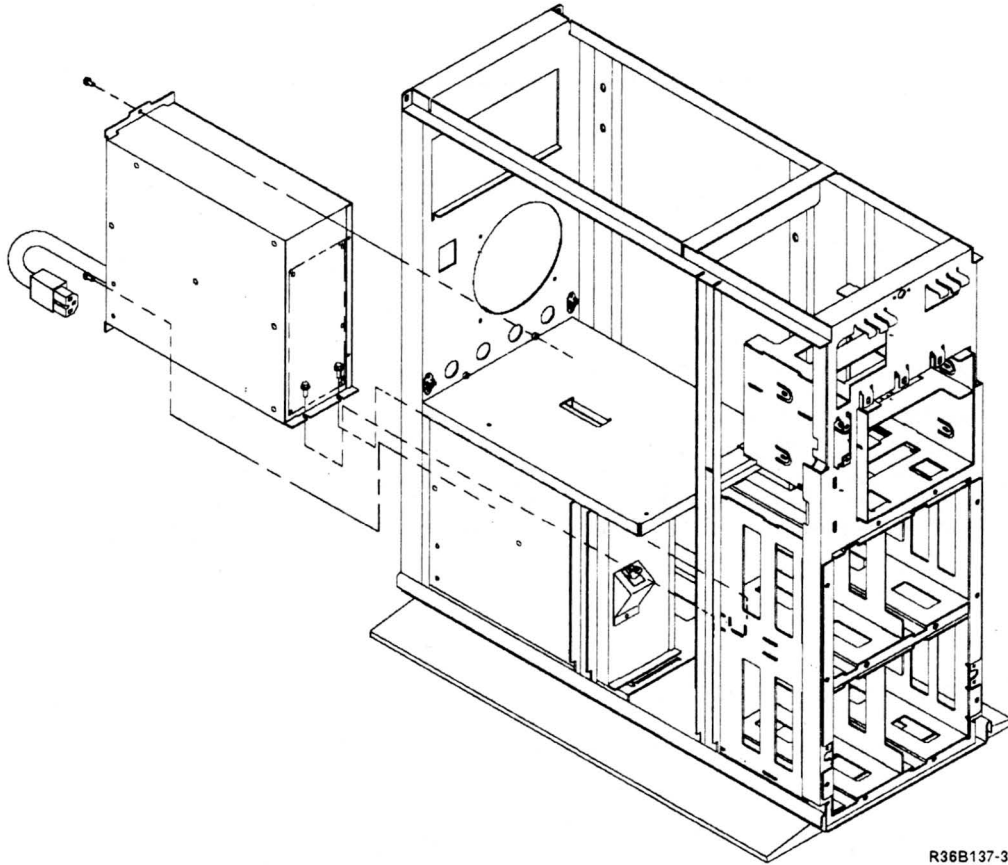

R36B137-3

6. Remove the two screws from the rear of the 5363 that hold the feature power supply, and the screws that hold the forward base tab of the power supply to the 5363 frame.
7. Slide the power supply toward the rear of the 5363 to clear the tabs on the frame and lift upward to remove.
8. Set the line voltage switch to the proper voltage for your 5363.
9. Install the new power supply by performing the previous steps in reverse order. Ensure that you slide the power supply under the tabs on the 5363 frame.

---

## 410 Power On/Off Actuator Switch and Cable Check Removal/Replacement Procedure

### Actuator/Cable Check Procedure

1. Power off the 5363 and disconnect the power cord at the customer power outlet.
2. Remove the covers ("305 Cover Removal" on page 3-2).
3. Rotate the cable coupler one-half turn counter clockwise to disconnect the cable from the power supply.
4. While setting the power switch on and off, check for cable movement of approximately 6.35 mm (1/4 inch) at power supply end.
5. If the cable does not move approximately 6.35 mm, disconnect the cable from the actuator.
6. Verify that the cable moves freely within the tube.
7. If the cable does not move freely, replace the cable. See "Actuator/Cable Removal/Replacement Procedure" in this procedure.
8. If the cable moves freely, check the actuator to verify that the actuator mechanism, when set on and off, is moving approximately 6.35 mm.
9. If the actuator does not move 6.35 mm, exchange the actuator. See "Actuator/Cable Removal/Replacement Procedure" in this procedure.
10. If both the cable and the actuator function correctly, connect the cable to the power supply and manually power on the power supply by pulling the cable approximately 6.35 mm.
11. If the cable can be moved the 6.35 mm, and the power supply does not power on, connect the cable to the actuator and go to "420 Power Supply FRU Isolation Procedure" on page 4-6.
12. If the cable can be moved the 6.35 mm, and the power supply does power on, connect the cable to the actuator, this procedure is then complete.

### Actuator/Cable Removal/Replacement Procedure

1. Power off the 5363 and disconnect the power cord at the customer power outlet.
2. Remove the covers ("305 Cover Removal" on page 3-2).
3. To remove the actuator, disconnect the cable from the actuator and remove two screws that attach the actuator to the 5363 frame.
4. To install the new actuator, perform the previous step in reverse order.
5. To remove the actuator cable from the actuator and the base power supply, rotate the couplers one half turn counter clockwise.
6. Lift out the power on/off cable assembly.
7. To install the new cable assembly, perform previous steps 6 and 5 in reverse order.

**Note:** When reinstalling the actuator into the 5363 frame, install the housing with bevelled edge facing up, and towards the diskette drive. If this note is not followed, the on and off switch setting will be reversed.

**Note:** Power switch has to be in the up or power on position to remove the cable.

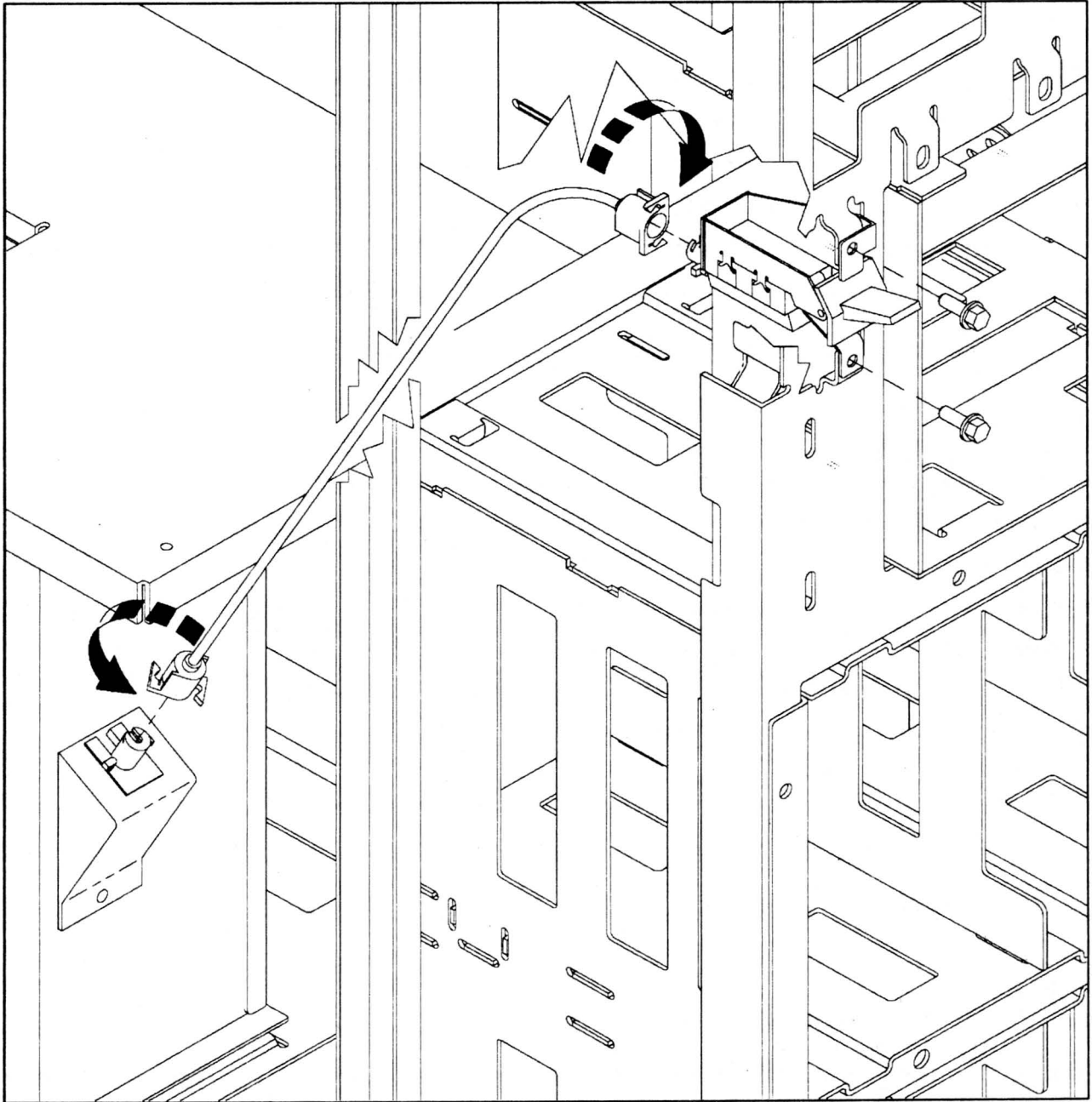

R36B156-1

## 420 Power Supply FRU Isolation Procedure

1. Power on the 5363.
2. Observe both the base power supply and the feature power supply fans:
  - If both fans are not turning, or if you only have a base power supply, go to step 3.
  - If the base fan is turning and the feature fan is not turning, go to step 19.
  - If the base fan is not turning and the feature fan is turning, go to step 8.
  - If both fans are turning, go to step 27.
3. Power off and disconnect the power cord at the customer power outlet and the 5363.
4. Use an ohmmeter to verify that the power cord does not have an open circuit.
  - If the power cord is OK, continue with the next step.
5. Unplug the feature power supply if one is present.
6. Check the power on/off actuator switch and cable assembly, ("410 Power On/Off Actuator Switch and Cable Check Removal/Replacement Procedure" on page 4-4). Then return to step 7.
7. Set the power on/off switch to the off position (O), reconnect the power cord, and go to step 9.
8. Power off the 5363.
9. If the base power supply is not part number 1035350, go to step 15. If it is, continue with the next step.
10. Remove connectors P1, P2, P3, P6, P7, and P8.
11. Power on the 5363 and check both fans.
12. If the base fan turns, continue with the next step.
  - If the base fan is not turning, exchange the base power supply ("405 Base Power Supply Removal" on page 4-2).
13. Power off the 5363.
14. Reinstall all the connectors you removed and continue with the next step.
15. For each of the cards and connectors in the following list, perform steps a through d:
  - a. Remove the card or connector.
  - b. Power on the 5363.
  - c. If the power on light is on, the FRU that is disconnected or the card that is removed is the failing FRU. Power off the 5363 and install a new card or FRU.
  - d. If the power on light is not on, power off the 5363, reinstall the connector or card, and repeat steps a through d for the next item on the list.
  - P6 to disk drive A
  - P8 to diskette drive
  - P7 to disk drive B (if installed)
  - J24 operator panel

**Note:** +5 volts to the power on light is disconnected when J24 connector is removed, check to see if the base power supply fan is running.

  - B1-G, J22 and A2 through K2 are located on the A1 board.
  - J22 to the 5363 fan
  - MSP data flow A1J2
  - MSP control A1H2
  - CSP A1G2

Work station adapter/control panel interface A1F2  
Work station controller A1E2  
Data storage adapter card A1D2  
Disk adapter A1C2  
Data storage adapter II card A1B2 (5363 II and IV)  
Disk adapter A1A2 (5363 II and IV)  
Main storage card (If B1 board is not present.)

**Note:** The cards and connectors to this point will isolate the base power supply.

16. To test for a defective power on light, do the following:
  - a. Power on the system. If the base power supply fan turns and the power on light is off, the light is defective or the distribution to the light is bad.
  - b. If the light is defective, exchange the control panel ("510 Control Panel Removal" on page 5-9).
  - c. For bad distribution to the light, check connectors and leads.
- If all of the above cards and connectors have been removed and the problem is still present, power off the 5363 and continue with the next step.
17. Exchange the Base power supply ("405 Base Power Supply Removal" on page 4-2). If problem is still present, continue with the next step.
18. Exchange the A1 board ("342 A1 Board Removal and Replacement Procedures" on page 3-19).
19. To isolate the feature power supply or parts attached, power off the 5363 and disconnect the power cord at the customer power outlet and the 5363.
20. Unplug the feature power supply.
21. With the power on/off switch set to the on position (I), verify continuity from J1 line to J2 line, and J1 neutral to J2 neutral on base power supply ("430 AC Point-to-Point" on page 4-10).

If you have continuity, continue with the next step.

If you do not have continuity, exchange the base power supply ("430 AC Point-to-Point" on page 4-10).

22. Set the power on/off switch to the off position (O) and reconnect the power cord and the feature power supply.
23. If feature power supply is part number 1035395 (or 1035526 for Europe Middle East and Africa) continue with the next step. If not, go to step 27.
24. Unplug P4, P5, P9, P10, and P11, and power on the 5363.
25. Observe the feature fan.

If the feature fan is turning, continue with the next step.

If the feature fan is not turning, exchange the feature power supply ("406 Feature Power Supply Removal" on page 4-3).
26. Power off the 5363, reinstall all the connectors you removed, and continue with the next step.
27. For each of the cards and connectors in the following list, perform steps a through d:
  - a. Remove the card or connector.
  - b. Power on the 5363.
  - c. If the feature fan is turning, the FRU that is disconnected or the card that is removed is the failing FRU. Power off the 5363 and install a new card or FRU.
  - d. If the feature fan is not turning, power off the 5363, reinstall the connector or card, and repeat steps a through d for the next item on the list.

P9 To disk drive C  
P10 To disk drive D  
P11 To tape drive

Main storage card B1-G

**Note:** The following cards must be installed in the indicated B1 board positions: The Feature IOP (B1-A) and Main Storage Card (B1-G). It is recommended that the Tape feature card be located in position (B1-F) for cable retention purposes. The other cards can be plugged in any remaining positions.

Feature IOP (1 each)

Local Area Network (LAN) (2 each possible)

Communications (2 each possible)

Tape (1 each possible)

28. If all of the cards and connectors have been removed and the problem is still present, exchange the feature power supply ("406 Feature Power Supply Removal" on page 4-3). If the problem is still present, replace the B1 board ("340 B1 Board Removal and Replacement Procedures" on page 3-17).
29. Reinstall the power connectors and go to "435 DC Voltage Distribution" on page 4-11 to check DC voltages.

## 425 Power Point-to-Point Overview

To determine point-to-point power flow, use the overviews, "430 AC Point-to-Point" on page 4-10, and "435 DC Voltage Distribution" on page 4-11.

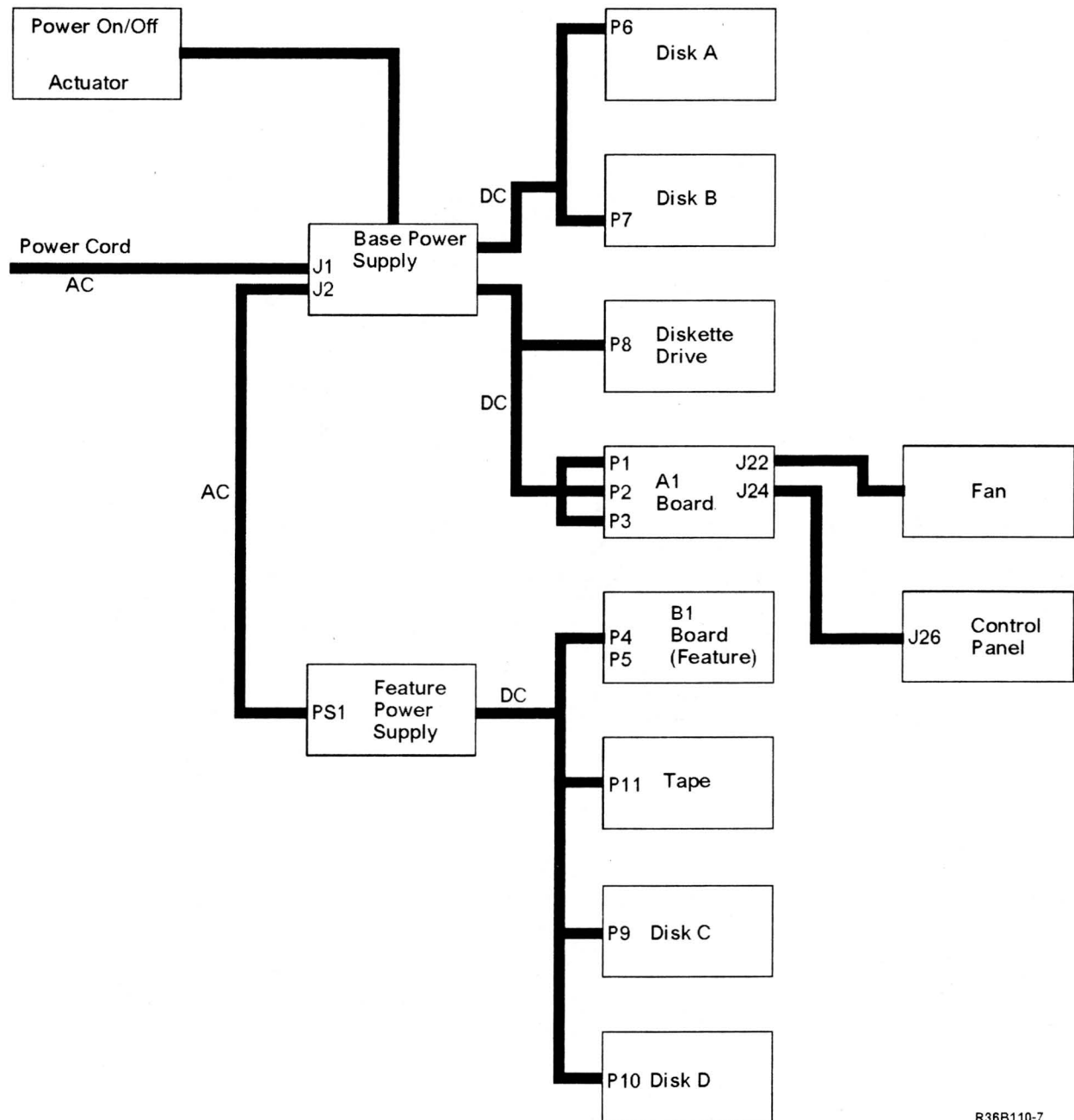

R36B110-7



# 430 AC Point-to-Point

All J-connectors on this page have green and yellow wires that are AC safety grounds. All AC safety grounds must be installed correctly. See Appendix A, "AC Safety Grounds" on page A-1 and "405 Base Power Supply Removal" on page 4-2.

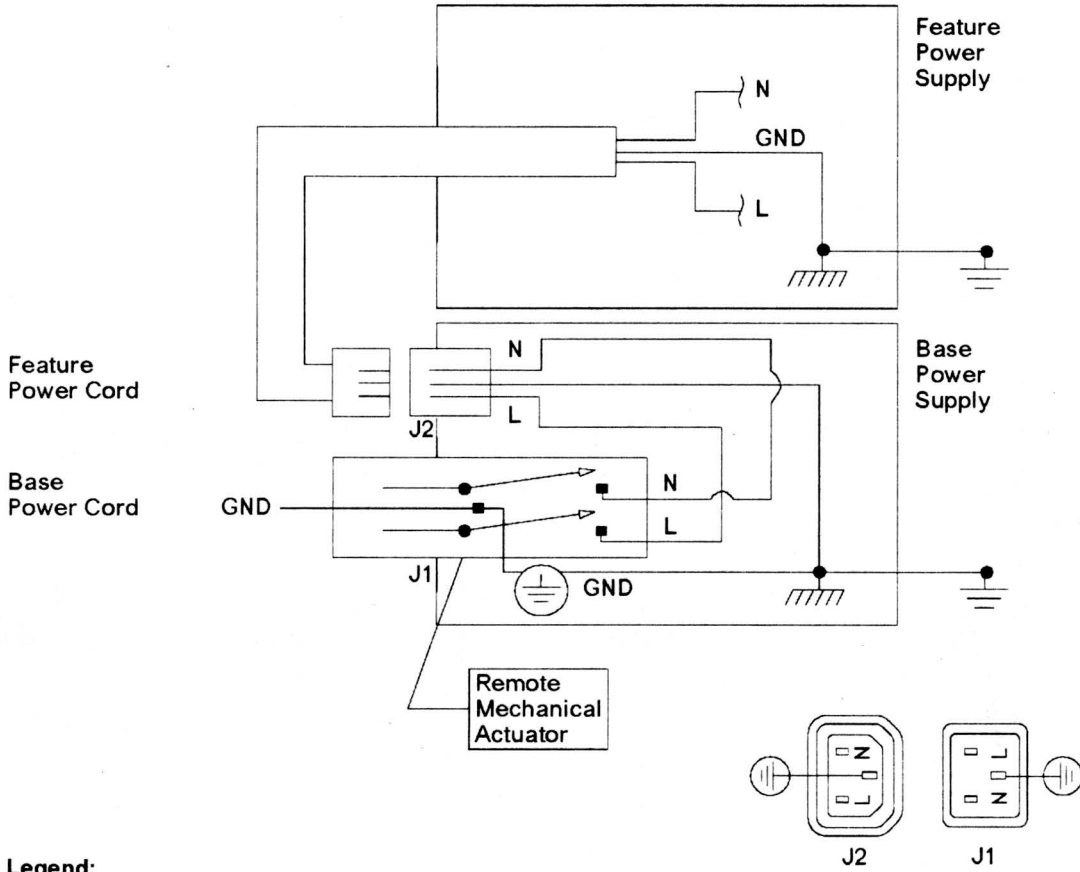
## AC Safety Grounds



**Legend:**

-  Chassis Ground
-  Frame or System Ground

R36B134-5

## 435 DC Voltage Distribution

### Base

Connector (Location)	Pin	Voltage
P1 (A1 Board)	1	+ 12 volts
	2	-12 volts
	3	+ PWR Good (+ 5 volts)
	4	-5 volts
P2 (A1 Board)	1	Ground
	2	Ground
	3	Ground
	4	+ 5 volts
	5	+ 5 volts
	6	+ 5 volts
P3 (A1 Board)	1	+ 1.7 volts
	2	+ 1.7 volts
	3	+ 1.7 volts
	4	RMT + 1.7
	5	RMT + 1.7 Common
	6	Ground
	7	Ground
	8	Ground
P6 (Disk Drive A)	1	+ 12 volts
	2	Ground
	3	Ground
	4	+ 5 volts
P7 (Disk Drive B)	1	+ 12 volts
	2	Ground
	3	Ground
	4	+ 5 volts
P8 (Diskette)	1	+ 12 volts
	2	Ground
	3	Ground
	4	+ 5 volts

Note: Pin positions are identified on page 4-12.

## Feature

Connector (Location)	Pin	Voltage
P4 (B1 Board)	1	-12 volts
	2	+ 12 volts
	3	+ PWR Good (+ 5 volts)
	4	-5 volts
P5 (B1 Board)	1	Ground
	2	Ground
	3	Ground
	4	+ 5 volts
	5	+ 5 volts
	6	+ 5 volts
P11 (Tape)	1	+ 12 volts
	2	Ground
	3	Ground
	4	+ 5 volts
P9 (Disk Drive C)	1	+ 12 volts
	2	Ground
	3	Ground
	4	+ 5 volts
P10 (Disk Drive D)	1	+ 12 volts
	2	Ground
	3	Ground
	4	+ 5 volts

Note: Pin positions are identified on page 4-12.

## Pin Positions

P6, P7, P8,  
P9, P10, P11

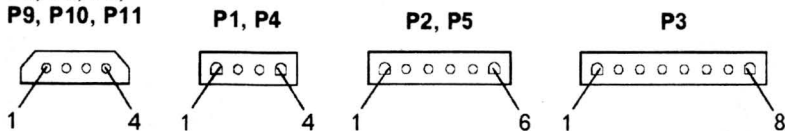

R36B157-1

---

## 440 Base and Feature DC Voltage Tolerances

The base and feature DC voltages can be measured at the connector pins shown in section 435.

Voltage	Minimum	Maximum
+1.7 volts	+1.66	+1.73
+5 volts	+4.80	+5.25
-5 volts	-4.60	-5.50
+12 volts See note.	+11.20	+12.60
-12 volts	-10.90	-13.20

**Note:** The +12 volts tolerances measured at P4 and P11 are minimum of +11.52 volts and maximum of +12.60 volts.

---

## 445 Maximum Ripple Voltage

The ripple voltage can be measured at the connector pins shown in the following tables:

**Note:** Ripple voltage must be measured with system in idle state (powered on, no exersisors active).

### A1 Board

Probe		Ground		Maximum Ripple
Connector	Pin	Connector	Pin	
P1	1	P2	1	200 millivolts
P1	2	P2	1	200 millivolts
P1	4	P2	1	100 millivolts
P2	4	P2	1	100 millivolts
P2	5	P2	2	100 millivolts
P2	6	P2	3	100 millivolts
P3	1	P3	6	50 millivolts
P3	2	P3	7	50 millivolts
P3	3	P3	8	50 millivolts

## B1 Board

Probe		Ground		
Connector	Pin	Connector	Pin	Maximum Ripple
P4	1	P5	1	200 millivolts
P4	2	P5	1	200 millivolts
P4	4	P5	1	100 millivolts
P5	4	P5	1	100 millivolts
P5	5	P5	2	100 millivolts
P5	6	P5	3	100 millivolts

## Disk Drive A

Probe		Ground		
Connector	Pin	Connector	Pin	Maximum Ripple
P6	1	P6	2	200 millivolts
P6	4	P6	3	100 millivolts

## Disk Drive B

Probe		Ground		
Connector	Pin	Connector	Pin	Maximum Ripple
P7	1	P7	2	200 millivolts
P7	4	P7	3	100 millivolts

## Disk Drive C

Probe		Ground		
Connector	Pin	Connector	Pin	Maximum Ripple
P9	1	P9	2	200 millivolts
P9	4	P9	3	100 millivolts

## Disk Drive D

Probe		Ground		
Connector	Pin	Connector	Pin	Maximum Ripple
P10	1	P10	2	200 millivolts
P10	4	P10	3	100 millivolts

## Diskette Drive

Probe		Ground		
Connector	Pin	Connector	Pin	Maximum Ripple
P8	1	P8	2	200 millivolts
P8	4	P8	3	100 millivolts

## Tape Drive

Probe		Ground		
Connector	Pin	Connector	Pin	Maximum Ripple
P11	1	P11	2	200 millivolts
P11	4	P11	3	100 millivolts



---

## **Section 5. Control Panel Procedures**

505	Control Panel Symptom Table	5-2
507	Control Panel Service Check	5-4
510	Control Panel Removal	5-9

## 505 Control Panel Symptom Table

Symptom	Information	Action
<p>The Console, Program, and Processor lights are all on.</p> <p>or</p> <p>The Output display contains less than four characters or a character that is not hexadecimal.</p>	<p>The control panel interface card failed the self-test.</p>	<p>Perform the following:</p> <ol style="list-style-type: none"> <li>1. Certain power supply faults can cause this problem. Verify that the voltage switches at the rear of the system unit are set to the correct voltage for your location. Measure the voltage on the following board power pins: A1-P1 pin 3, A1-P2 pin 4, A1-P2 pin 5, and A1-P2 pin 6. Measure the voltage on B1-P4 pin 3 and B1-P5 pin 5. See "435 DC Voltage Distribution" on page 4-11. The voltage measured on all of the above pins should be between 4.5 and 5.5 volts. If the above measured voltages do not meet criteria, go to "420 Power Supply FRU Isolation Procedure" on page 4-6, or continue with step 2.</li> <li>2. Exchange the following FRUs, one at a time, in this sequence:               <ol style="list-style-type: none"> <li>a. A1F2 work station adapter/control panel interface card</li> <li>b. A1G2 CSP card</li> <li>c. A1 Board</li> </ol> </li> <li>3. Load the system from disk ("330 Loading the DCP from Disk" on page 3-14) or diskette 61 ("332 Loading the DCP from Diskette" on page 3-14) to verify the repair.</li> </ol>
<p>The control panel does not operate correctly.</p>	<p>The control panel and the control panel interface card are not communicating.</p>	<p>Go to "507 Control Panel Service Check" on page 5-4.</p>
<p>The system will not function.</p>		<p>Go to "507 Control Panel Service Check" on page 5-4.</p>
<p>A system power problem is present.</p>		<p>Go to "507 Control Panel Service Check" on page 5-4.</p>

Symptom	Information	Action
<p>The control panel is not operating, and the system appears to be stopped.</p>	<p>The CSP can be in a program loop while performing a control panel instruction.</p>	<p>Perform the following to stop the program loop:</p> <ol style="list-style-type: none"> <li>1. Set the Power Switch to the Off (O) position.</li> <li>2. Wait 5 to 10 seconds.</li> <li>3. Set the Power Switch to the On (I) position.</li> <li>4. Load the system from disk and run SYSTEST, see "328 Service Procedures under SSP" on page 3-11 to verify correct operation.</li> </ol>

## 507 Control Panel Service Check

### Notes:

1. This service check needs a dedicated system. Ensure that the customer has ended all jobs and closed all files.
2. Power off the 5363 before exchanging FRUs.
3. When this service check instructs you to exchange the control panel, see "510 Control Panel Removal" on page 5-9.
4. Perform this service check to verify any repair.

This service check tests the following control panel functions:

- Security switch
- Lamp test
- Select Function key/Input key
- Display key

You must perform this service check in the sequence given.

### 1. Power Off/Power On Test

- a. Set the Security switch to the Service position.

If the system is powered on, go to step 1c. If the system is powered off, go to step 1b.

- b. Power on the 5363 system.

- c. If the Power On light is on, continue with step 1d. If the Power On light is not on, record a power SRC of 9901. Suspect the following FRUs:

%	FRU
66	Power supply
18	Control panel
8	Operator panel cable
8	Power cord

- d. If the Power On light remains on, go to step 2. If the Power On light goes off, record a power SRC of 9901 and go to step 1e.

**Note:** Customer data can be lost if jobs are not ended and files are not closed before powering off.

- e. Power off, and continue with step 1f. If the system does not power off, record a power SRC of 990A and go to step 1g.

f. The control panel is not operating correctly. Suspect the following FRUs:

%	FRU
75	A1F2 WSA/control panel interface card
10	Control panel
10	A1G2 CSP
5	Operator panel cable

g. Suspect the following FRUs:

%	FRU
80	Base power supply
20	Operator panel cable

## 2. Security Switch Test

- Set the Security switch to the Normal position. If the Power On light is the only light or display that is on, go to step 3. If not, find the control panel lights that are on in the table below and go to the indicated step.
- The 5363 will power up with the Security switch in the locked position; however, the Select Function and the Start Function keys are inoperable.

Control Panel Lights On	Go to Step
Console, Program, and Processor	2c
Console	2d
Program	2d
Processor	2d
Displays	2d

c. Suspect the following FRUs:

%	FRU
80	A1F2
15	Base power supply
5	A1G2 CSP card

d. Suspect the following FRUs:

%	FRU
75	Control panel
20	A1F2
5	Operator panel cable

### 3. Lamp Test

- a. Set the Security switch to the Service position. Press the Select Function key and select function 8 (Lamp Test). Then, press the Start Function key.

If all of the control panel lights go on and an 8 appears in all of the displays, the control panel is correct. Continue with step 3b. If the control panel is not correct, go to step 6.

If you cannot select and start function 8, suspect the following FRUs:

%	FRU
85	Control panel
10	A1F2
5	Operator panel cable

- b. Press the Start Function key several times.

If only the 8 in the Function display blinks, the control panel is correct. Continue with step 4. If the 8s in the Input displays blink, the control panel is not correct. Suspect the following FRUs:

%	FRU
85	Control panel
10	A1F2
5	Operator panel cable

### 4. Select Function Key/Input Key Test

- a. Press the Select Function key and select function 1 (IPL).

If a 1 appears in the Function display and 0's appear in the Input displays, the control panel is correct. Continue with step 4b.

If the control panel is not correct, go to step 4d.

- b. Press and hold the Select Function key. Repeat several times.

If only the Function display loops characters 1 through E, the control panel is correct. Continue with step 4c. If the control panel is not correct, go to step 4d.

- c. Press the Select Function key and select function 1 (IPL). Press and hold, in sequence, each of the four input keys. Repeat several times.

If only the Input display above the Input key you press loops characters 0 through F, the control panel is correct. Go to step 5. If the control panel is not correct, continue with step 4d.

- d. The control panel is not operating correctly. Suspect the following FRUs:

%	FRU
70	Control panel
25	A1F2
5	Operator panel cable

## 5. Display Key Test

- a. Press the Select Function key and select function E (Compare Address and Stop).
- b. Press the Display key.

If the Output display is blank, except for a 0 or 1 in the rightmost position, the control panel is correct. Continue with step 5b. If the control panel is not correct, suspect the following FRU:

%	FRU
99	A1F2

If the Output Display light goes on, continue with step 5c. If the Output Display light does not go on, go to step 5d.

- c. Press the Display key again.

If the Output Display light goes off, go to step 5e. If the Output Display light does not go off, continue with step 5d.

- d. The control panel is not operating correctly. Suspect the following FRUs:

%	FRU
85	Control panel
10	A1F2
5	Operator panel cable

- e. Set the Security switch to the Normal position (only the Power On light is on). Press each of the four input keys and the Display key several times.

If the control panel does not change, go to "105 System Entry Procedure" on page 1-5. If the control panel changes in any way, or if the Power On light was not the only light on, suspect the following FRUs:

%	FRU
85	Control panel
10	A1F2
5	Operator panel cable

## 6. Lamp Test Failed

- a. Find the lamp test failure in the table below and go to the indicated step.

Lamp Test Failure	Go to Step
Blank panel (power on only).	6b
8 is in the Function display only.	6b
One or more Input displays do not show an 8.	6c
One or more of the Console, Program, and Processor lights are not on.	6b
The failure is not in this list.	6c

- b. Suspect the following FRUs:

%	FRU
75	A1F2
20	Control panel
5	Operator panel cable

- c. Suspect the following FRUs:

%	FRU
80	Control panel
15	A1F2
5	Operator panel cable

## 510 Control Panel Removal

1. Power off the 5363.
2. Remove the covers ("305 Cover Removal" on page 3-2).
3. Support the control panel from the front of the system. Remove the two mounting screws that attach the control panel to the frame. You can reach the screws from inside the system.
4. Disconnect the three wires to the Security switch:
  - Black wire to position 1
  - Red wire to position 3
  - White wire to position 5
5. Carefully lift each of the two latches on the bottom of the bezel. Lift each latch only enough to release the bottom of the control panel, then remove the bezel.
6. Disconnect JC1.
7. Install the control panel by doing the previous steps in reverse order.

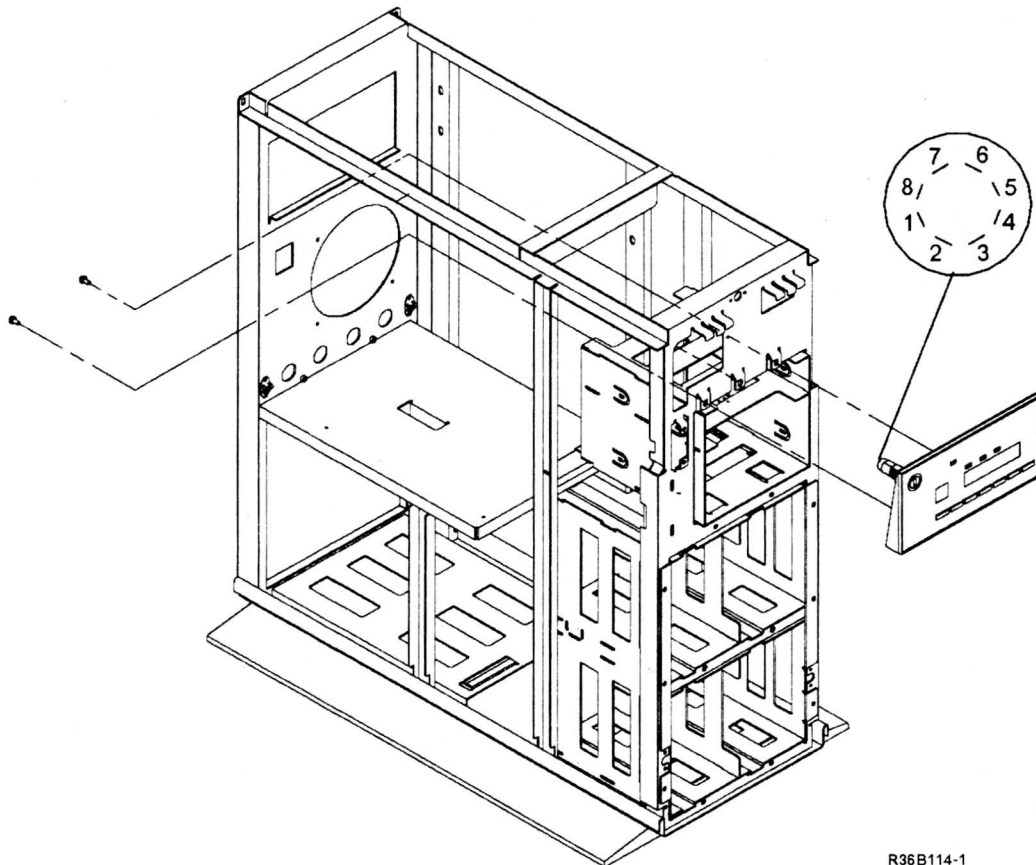

R36B114-1



---

## **Section 6. Diskette Procedures**

- 602 Isolating Diskette Drive Problems 6-2
- 604 Voltage Check 6-3
- 606 Diskette Drive Removal 6-3

## 602 Isolating Diskette Drive Problems

Symptom	Action
<p>Intermittent diskette drive errors.</p> <p><b>Note:</b> Radio frequency interference (RFI) may cause errors on the diskette drive when the 5363 cover is removed.</p>	<p>Display the Error History Table to see if a FRU is identified by any SRCs that are shown see "360 Getting ERAP Reports" on page 3-25.</p> <ol style="list-style-type: none"><li>1. Power off the 5363.</li><li>2. Remove the covers ("305 Cover Removal" on page 3-2).</li><li>3. Reseat the cards and cables in the 5363.</li><li>4. Reinstall the covers.</li><li>5. Power on the 5363.</li><li>6. Perform an IPL of the 5363 from diskette 61, select function 3, enter 0000.</li></ol> <p>If an SRC is displayed, exchange the FRU indicated.</p> <p>Run SYSTEST for 10 minutes to verify the problem is fixed. See "328 Service Procedures under SSP" on page 3-11.</p> <p><b>Note:</b> Customer problem determination attempts to isolate problems to the diskette drive or the diskettes being used. If you want to run the diskette tests, enter TESTDSKT ("328 Service Procedures under SSP" on page 3-11) on the command line and press the Help key.</p>
<p>Cannot perform an IPL from diskette.</p>	<p>If you cannot perform an IPL from diskette, and no SRCs are generated, suspect the following:</p> <ul style="list-style-type: none"><li>Missing voltage</li><li>Data storage adapter card</li><li>Diskette drive</li><li>Diskette cable assembly</li></ul> <p><b>Note:</b> Customer problem determination attempts to isolate problems to the diskette drive or the diskettes being used. If you want to run the diskette tests, enter TESTDSKT ("328 Service Procedures under SSP" on page 3-11) on the command line and press the Help key.</p>

---

## 604 Voltage Check

The system supplies DC voltage to the diskette drive through connector P8. P8 connects to the drive control card through the I/O connector pins (I/O CP) **E**. (Measure voltages at test points on diskette drive.) In World Trade countries, remove the ESD protection shield before verifying the voltages. Use a multimeter to verify the voltages.

If the voltages are missing or not correct, exchange the base power supply ("405 Base Power Supply Removal" on page 4-2).

If the voltages are correct, exchange the A1D2 card or the diskette drive ("606 Diskette Drive Removal").

Voltage	I/O CP <b>E</b> P8
+ 12 vdc	1
Ground	2
Ground	3
+ 5 Vdc $\pm 0.5$ V	4

---

## 606 Diskette Drive Removal

1. Power off the 5363 and disconnect the power cord at the customer power outlet and the 5363.
2. Remove the covers ("305 Cover Removal" on page 3-2).
3. Remove the four mounting screws (two on each side) from the diskette drive.
4. Slide the diskette drive slightly forward to permit access to the cables.
5. Disconnect the P8 power plug and the signal cable.
6. Remove the ESD protection shield (World Trade only).
7. Remove the diskette drive by sliding the unit towards you until it is out of the 5363 frame.
8. Install the diskette drive by doing the previous steps in reverse order.

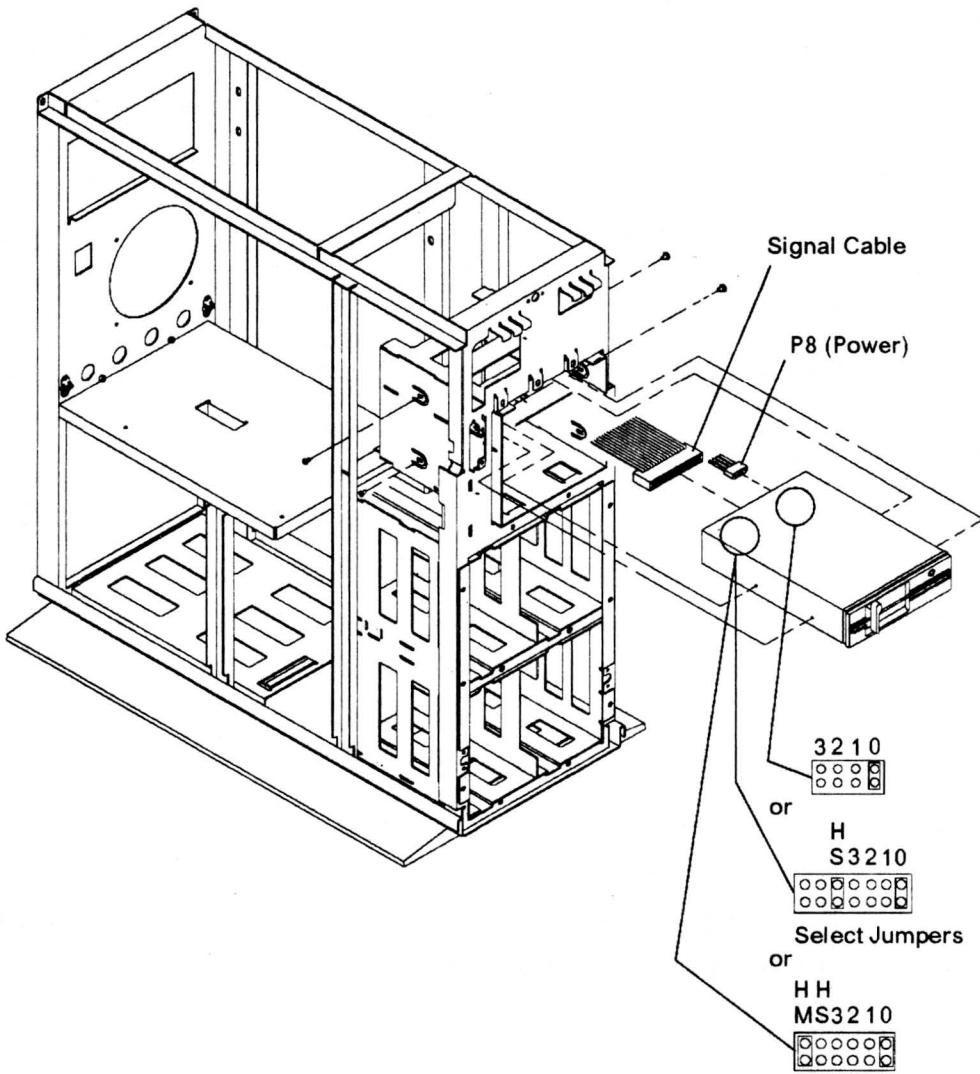

R36B115-2

**Note:** Ensure that the select jumper is connected to select drive 0.

---

## **Section 7. Local Work Station Procedures**

- 706 Local Work Station Network Analysis Procedure 7-2
- 710 Local Work Station Cable Signal Quality Check 7-3
- 712 Sample Oscilloscope Signals 7-10
- 714 Local Work Station Cable Ohmmeter Test 7-15

---

## 706 Local Work Station Network Analysis Procedure

The system console must be working before this procedure can be used. Also, you need to know the addresses of the work stations that are attached to the system. The customer should give you this information.

This procedure uses the network analysis option of the DCP Main menu to isolate local work station problems. The network analysis option displays a matrix on the system console. The matrix shows:

- The cable and station addresses of all possible work stations across the top of the matrix.
- The conditions sensed for each address down the side of the matrix.

An X is placed at the position of the work station address and the condition that was sensed. The correct responses are as follows:

- Work station display: An X in the single-frame condition row.
- Work station printer: An X in the single-frame condition row for the first sense and an X in the multiframe condition row for following senses.
- No work station at the address: An X in the no-response row.

The following FRUs are partially tested:

- A1F2 work station adapter/control panel interface
- A1E2 work station pass-through or work station controller
- Work station controller card (A1E2): The controller card is used only on systems with the work station expansion feature. (28 local work stations)
- Work station pass-through card (A1E2): The pass-through card is used only on base systems. (16 local work stations)
- Internal cable to workstation ports.
- A1 board
- Twinaxial cables
- Work stations

### To run network analysis:

1. Ensure that the Security switch is in the Service position.
2. Insert diskette 61.
3. Select function 3 (IPL Diskette).
4. Enter 0000.
5. Press the Start Function key.
6. When the DCP Main menu appears on the system console, select the network analysis option.  
The system displays a status matrix on the console after approximately 30 seconds.
7. Use the following table and the matrix that is displayed to isolate the failure.
8. To end network analysis, load the system again ("320 Loading the SSP" on page 3-8). Verify that the system is operating correctly.

Condition Sensed	Failing FRU or Action
RCV buffer overrun	A1E2, A1F2.
Single-frame or multiframe	<p>If the condition was sensed at an address where there is no work station, ensure that:</p> <ol style="list-style-type: none"> <li>1. The cable is connected to the correct port at the system.</li> <li>2. The address switches on the work station are set correctly.</li> <li>3. The terminator switch on the work station is set correctly.</li> </ol> <p>If a work station display responded with a multiframe condition, see the device maintenance manual to isolate the failure. A multiframe response from a work station display is not valid.</p> <p>If a work station printer failed to respond with the multiframe condition, see the device maintenance manual to isolate the failure. The work station printer failed to perform the modeset command.</p>
No response	<p>If a work station did not respond:</p> <ol style="list-style-type: none"> <li>1. Verify that the work station is powered on and is in a Ready condition (not in setup or test mode).</li> <li>2. Verify that the address and terminator switches are set correctly.</li> <li>3. If the above steps are OK, exchange A1F2 or A1E2.</li> <li>4. Check the twinaxial cable ("714 Local Work Station Cable Ohmmeter Test" on page 7-15 and "710 Local Work Station Cable Signal Quality Check").</li> </ol> <p>If a work station printer failed to respond, also see the action under single-frame or multiframe condition.</p>
Serial parity check	A1F2 or A1E2.
Driver activity check	A1F2, A1E2, or a short circuit in one of the work station cables.

## 710 Local Work Station Cable Signal Quality Check

### DANGER

**Do not work with cables during an electrical storm.**

\_\_\_\_\_

\_\_\_\_\_

\_\_\_\_\_

For an alternative method of checking the cable, see "714 Local Work Station Cable Ohmmeter Test" on page 7-15.

Installing and maintaining the cable is a customer task. However, if aid is requested, see the following manuals for additional information:

- For more information on twinaxial cabling, see the *IBM 5250 Information Display System Planning and Site Preparation Guide*, GA21-9337.

- For more information on the IBM Cabling System, see the *IBM Cabling System Planning and Installation Guide*, GA27-3361, and the *IBM Cabling System Problem Determination Guide for Twinaxial Applications*, GA21-9491.
- For more information on telephone twisted pair cabling, see the *IBM 5299 Model 3 Terminal Multi Connector and IBM Twinaxial to Telephone Twisted Pair Adapter Planning, Installation, and Problem Analysis Guide*, GA27-3749.

The cable signal quality check determines if a failure is present in the cable, the cable connectors, or an attached work station. This test sends a signal down the cable, using the square wave from the B-gate output on the oscilloscope. Signal paths up to a maximum of 1524 meters (5000 feet) can be checked.

It is normal for a surge suppressor to cause a glitch of the signal. See sample oscilloscope signals **E** and **H**. See "712 Sample Oscilloscope Signals" on page 7-10.

## Defective Cables

If the cable is terminated by the correct load impedance, all the power of the transmitted signal is used by the terminating impedance.

If there is a cable failure that changes the impedance of the cable, part of the signal is returned to the signal source as a reflection.

A short circuit in the cable causes the impedance to be lower than normal. This causes a decrease in the amplitude of the signal.

An open circuit in the cable causes the impedance to be higher than normal. This causes an increase in the amplitude of the signal.

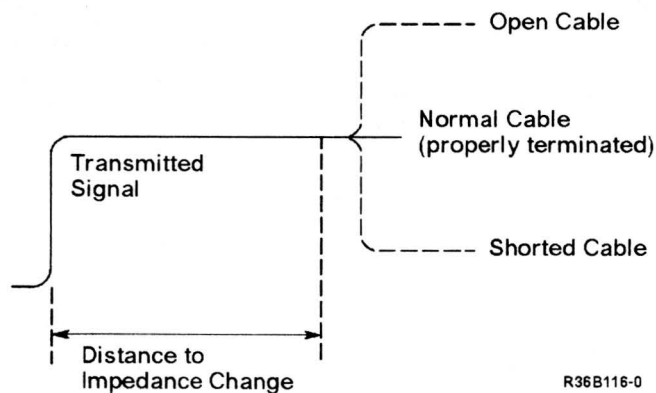

## Test Equipment Needed

To perform the cable signal quality check, you should have the following (or similar) equipment:

- One Tektronix 453, 454, or 475 oscilloscope. (This procedure uses the 475 oscilloscope.)
- One BNC T-connector (part 1650289).
- One probe-tip-to-BNC adapter (part 453199).
- One coaxial cable with a BNC end and alligator clips (part 1650290), or a BNC-to-banana-plug adapter and multimeter leads.
- One times 1 (X1) probe (a times 10 (X10) probe may be used by changing the vertical input setting).

- Cable termination on the cable being checked. See step 5 of the setup procedure that follows.

## Setup Procedure

1. Set the scope switches as follows:

CH 1 VOLTS/DIV: 0.5 volts  
 AC-GND-DC: AC  
 INVERT: Inverted (out)  
 VERT MODE: CH 1  
 A and B TIME/DIV  
 and DELAY Time:  
 Set A to 10 microseconds,  
 pull knob to unlock, and  
 set B to 2 microseconds.  
 HORIZ DISPLAY: B DLY'D  
 TRIG MODE: AUTO  
 COUPLING: AC  
 SOURCE: STARTS AFTER DELAY  
 SLOPE: Minus

2. Attach the T-connector **A** to B + GATE on the rear panel of the oscilloscope.
3. Use the probe tip adapter **B** (part 453199) to attach the channel 1 probe to one side of the T-connector.
4. Attach the probe **C** (part 1650290) to the other side of the T-connector.
5. If you are checking an IBM Cabling System, go to step 7. For twinaxial cables, continue with step 6.

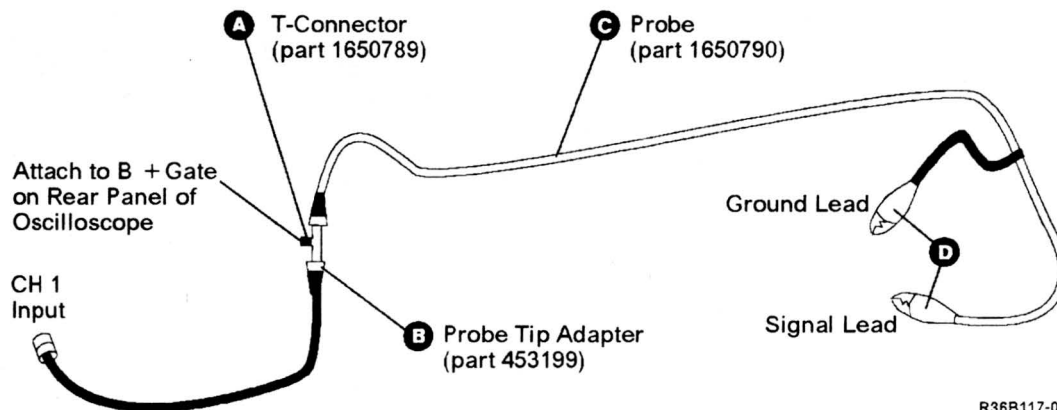

## 6. Twinaxial Cable:

Ensure the cable is attached to a work station. If the Cable Thru feature is present, ensure the cable is attached to the last work station on the port and set the terminator switch on the last work station to 1.

To check a cable not attached to a work station, terminate the end of the cable with a resistor assembly (part 7362344) as shown here:

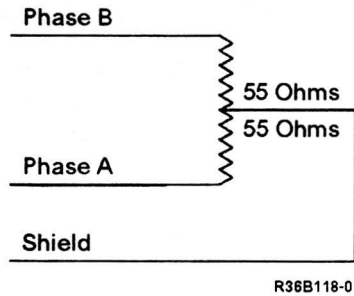

Go to step 8 on page 7-7.

## 7. IBM Cabling System:

Ensure the cable from the IBM Cabling System outlet to the work station is part 6111020 (impedance matching).

If the Cable Thru feature is present, ensure the cable from the IBM Cabling System outlet to the work station is part 6111025 (direct connect). Set the terminator switch to the not terminated position and connect the twinaxial terminator (part 6111028) to port 2 on the work station.

If you want to test a cable that is not attached to a work station, terminate the end of the cable with a 75-ohm resistor assembly as follows:

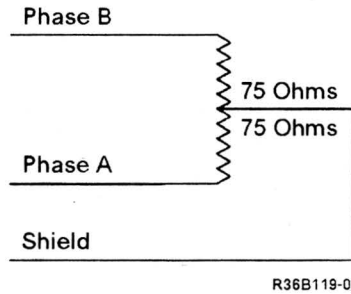

8. Disconnect the cable to be checked from the system. Connect the alligator clips **D** on the probe to the end of the cable for each of the following combinations:

- Ground lead to shield, signal lead to phase A.
- Ground lead to shield, signal lead to phase B.
- Ground lead to phase A, signal lead to phase B.

Look at the oscilloscope signal to determine if a cable failure is present. Use the tables and the sample oscilloscope signals on the following pages to find any problems that are present. The sample oscilloscope signals shown are for twinaxial cable. IBM Cabling System oscilloscope signals are similar.

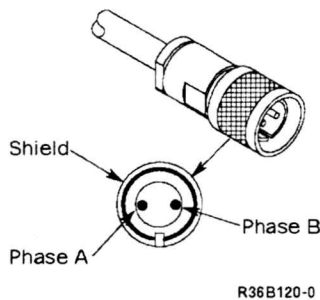

## Adjusting the Oscilloscope

Display	Action
No reflection. See <b>A</b> and <b>B</b> "712 Sample Oscilloscope Signals" on page 7-10.	If the B-sweep time/div is set on 2 microseconds, the maximum cable length of 1524 meters (5000 feet) is displayed. No reflection indicates that the cable is good, if all the combinations in step 6 have been checked.
Multiple reflections. See <b>D</b> and <b>G</b> "712 Sample Oscilloscope Signals" on page 7-10.	Decrease the B-sweep time/div so that only a single reflection is displayed. See the action for single reflections.
Single reflections. See <b>C</b> , <b>E</b> , <b>F</b> , and <b>H</b> "712 Sample Oscilloscope Signals" on page 7-10.	Measure the time divisions on the oscilloscope to the point where the signal level just starts to change either upward or downward. Use the distance table on the following page to find the distance to the cable failure.

### Notes:

1. To increase the size of small changes, move the signal down (channel 1 Position knob) and decrease the channel 1 volts/div setting.
2. For long cables, failures at the far end may not be easy to see on the oscilloscope. Reconnect the cable to the system and disconnect or remove the terminating resistor from the other end of the cable. Repeat step 8 of the setup procedure.
3. Failures too close to the tested end of the cable cause reflections to occur during the rise time of the oscilloscope.
4. If you suspect that the cable is too long and you want to check the length, disconnect or remove the terminating resistor from the other end of the cable. Repeat step 8 of the setup procedure. The oscilloscope will show an open circuit, as shown in **C** or **D**. See "712 Sample Oscilloscope Signals" on page 7-10.

## Calculating the Distance to the Failure

For twinaxial cable, the total signal path length equals the total cable length.

For the IBM Cabling System, the total signal path is longer than the total cable length. For each cable from the distribution panel to a work station (except for the last work station or the only work station on the port), the signal path is twice the length of the cable. You must use the total length of the signal path, not the length of the cable, to find the failure.

For the diagram on the next page, the total cable length is 290 meters (951 feet):  $200\text{ m} + 25\text{ m} + 35\text{ m} + 30\text{ m} = 290\text{ meters}$ .

To determine the total signal path, use the following procedure:

1. Add together the lengths of the cables from the distribution panel to all the work stations except the last.
2. Multiply the total from step 1 by 2.
3. Add the length of the cable between the distribution panel and the last work station to the total from step 2.
4. Add the length of the cable between the distribution panel and the system to the total from step 3.

For the diagram on the next page, this results in a total signal path of 350 m (1148 feet), as follows:

1.  $25\text{ m} + 35\text{ m} = 60\text{ m}$

2.  $60\text{ m} \times 2 = 120\text{ m}$
3.  $30\text{ m} + 120\text{ m} = 150\text{ m}$
4.  $200\text{ m} + 150\text{ m} = 350\text{ m}$

**To calculate the distance to the failure:**

1. Determine the time in divisions between the start of the + B-Gate squarewave and the reflection caused by the failure.  
For example, sample oscilloscope signal **C** ("712 Sample Oscilloscope Signals" on page 7-10) shows 6.4 divisions to the reflection caused by the open.
2. Multiply the number of divisions times the length per division for the B-sweep setting shown in the following distance tables.

Sample oscilloscope signal **C** has a B-sweep setting of 2.0 microseconds. Therefore, the distance to the failure would be 1267 meters for a twinaxial cable ( $6.4 \times 198$ ) and 1420 meters for an IBM Cabling System ( $6.4 \times 222$ ).

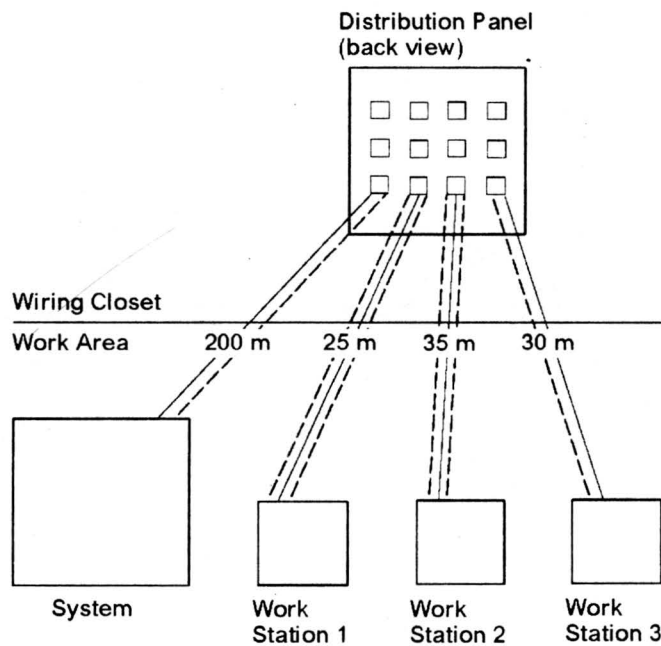

**Legend:**

- Cable
- Data Signal Path
- m = meters

R36B121-1

### Distance Table for Twinaxial Cables

B-Sweep Setting (Microseconds)	Meters (Feet)/Div	Maximum Cable Displayed (10 Divisions)
2.0	198 (649.4)	1980 meters (6494 feet) – Maximum cable length permitted is 1524 meters (5000 feet)
1.0	99 (324.7)	990 meters (3247 feet)
0.5	49.5 (162.4)	495 meters (1624 feet)
0.2	19.8 (64.9)	198 meters (649 feet)
0.1	9.9 (32.5)	99 meters (325 feet)

### Distance Table for IBM Cabling System

B-Sweep Setting (Microseconds)	Meters (Feet)/Div	Maximum Cable Displayed (10 Divisions)
2.0	222 (730)	2220 meters (7300 feet) – Maximum data signal path length permitted is 1524 meters (5000 feet)
1.0	111 (365)	1110 meters (3650 feet)
0.5	55.5 (182.5)	555 meters (1825 feet)
0.2	22.2 (73)	222 meters (730 feet)
0.1	11.1 (36.5)	111 meters (365 feet)

## 712 Sample Oscilloscope Signals

### A Cable OK (1511 meters/4950 feet)

0.5 volts/div

A = 10 microseconds

B = 2 microseconds

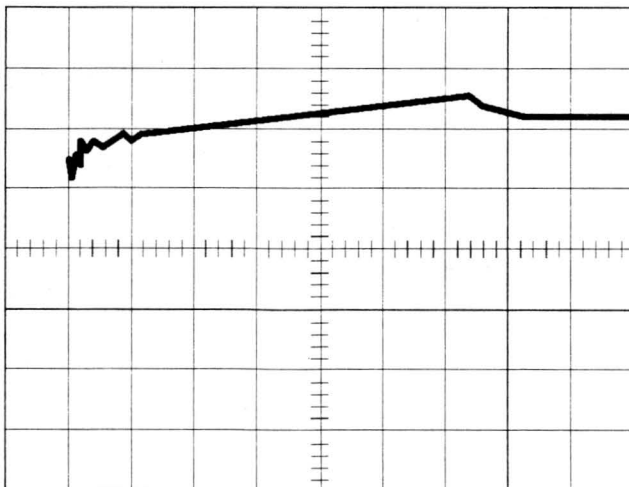

R36B122-0

**B Cable OK (15.2 meters/50 feet)**

0.2 volts/div

A = 10 microseconds

B = 2 microseconds

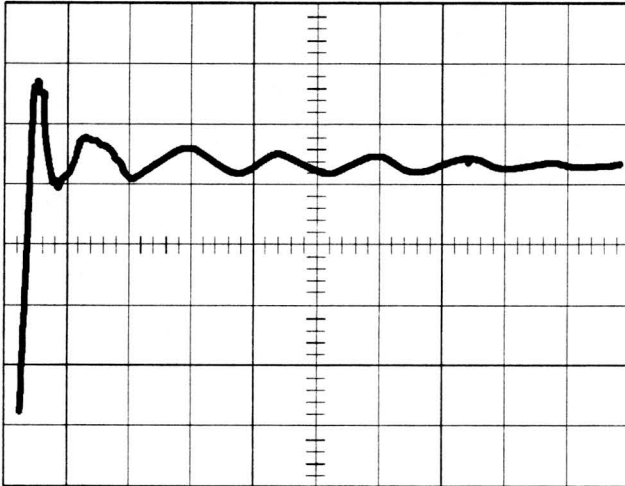

R36B124-0

**C Open Circuit (one reflection)**

0.5 volts/div

A = 10 microseconds

B = 2 microseconds

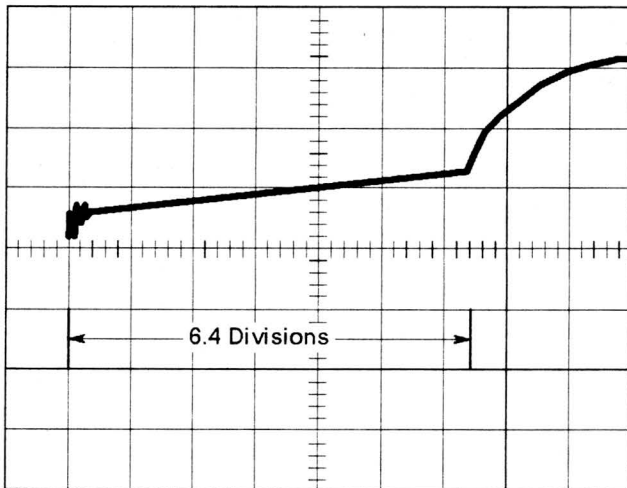

R36B123-0

**D Open Circuit (multiple reflections)**

0.5 volts/div

A = 10 microseconds

B = 2 microseconds

Change B to 0.1 microsecond (see **E**).

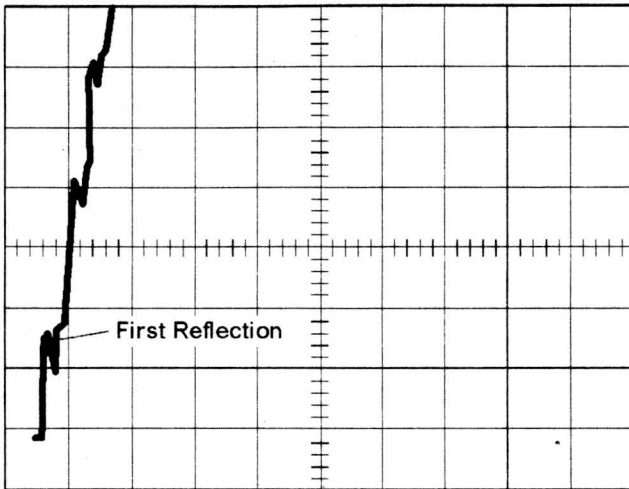

R36B125-0

**E Open Circuit (one reflection)**

0.5 volts/div

A = 10 microseconds

B = 0.1 microsecond

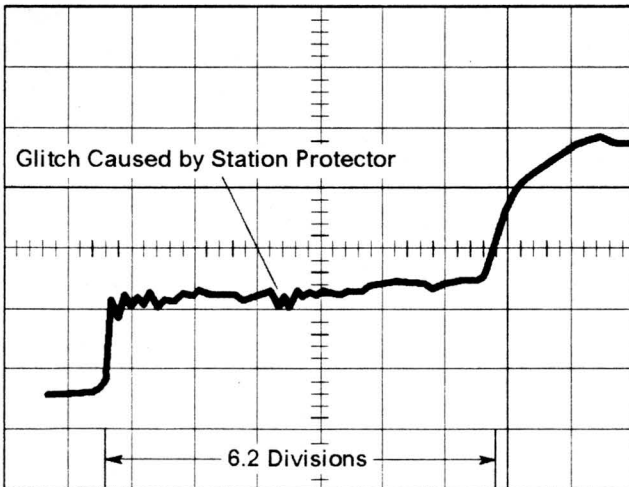

R36B126-0

**F Short Circuit (one reflection)**

0.5 volts/div

A = 10 microseconds

B = 2 microseconds

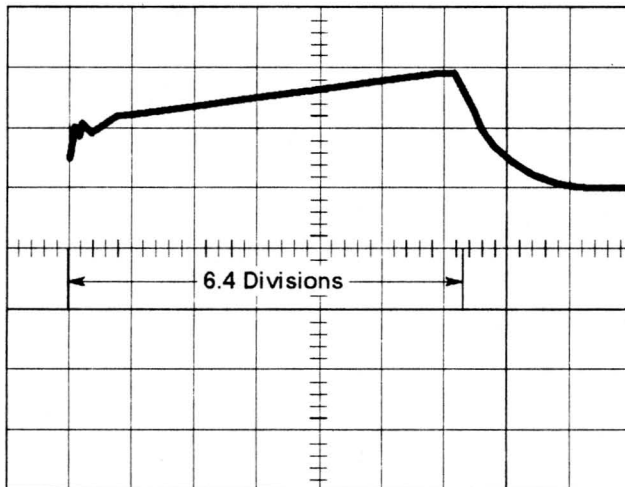

R36B128-0

**G Short Circuit (multiple reflections)**

0.5 volts/div

A = 10 microseconds

B = 2 microseconds

Change B to 0.1 microsecond (see **H**).

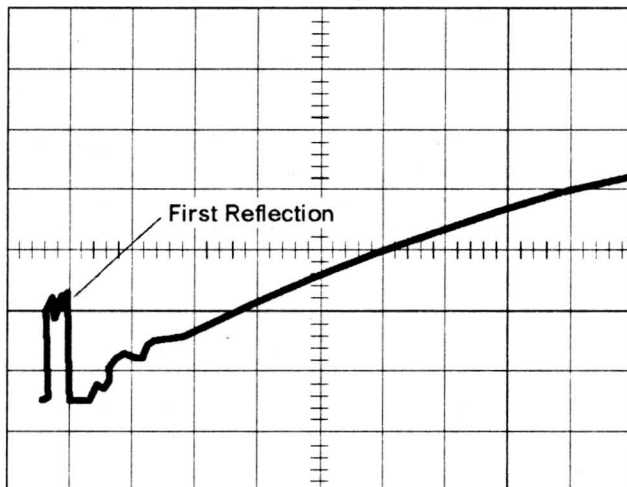

R36B127-0

**H Short Circuit (one reflection)**

0.5 volts/div

A = 10 microseconds

B = 0.1 microsecond

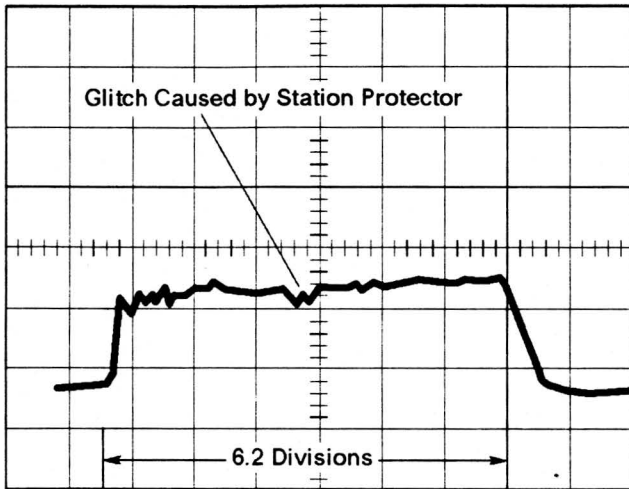

R36B129-0

## 714 Local Work Station Cable Ohmmeter Test

### DANGER

**Do not work with cables during an electrical storm.**

Station protectors must be removed before using this procedure.

1. Set the ohmmeter to the times 10 (x10) scale.
2. Disconnect the cable to be checked from the system unit.
3. Measure the resistance between each pin of the cable and the ground shield of the cable. This measurement assumes a properly terminated display and printer.
  - a. If the resistance is less than 20 ohms (short circuit) or more than 200 ohms (open circuit), repair or exchange the cable.
  - b. Verify that the display protectors are present if resistance is more than 200 ohms (open circuit).
4. Measure the resistance between the two pins of the cable.

If the resistance is less than 80 ohms (short circuit), repair or exchange the cable.
5. Disconnect the cable being checked from the last work station on the port. The system unit end of the cable should still be disconnected.
6. Measure the resistance between each pin of the cable and the ground shield of the cable.

If the resistance is less than 200 ohms (short circuit), repair or exchange the cable. A low resistance can also be caused by a terminating resistor on the plannar board in a display station.
7. Measure the resistance between the two pins of the cable.

If the resistance is less than 200 ohms (short circuit), repair or exchange the cable.
8. At the work station end of the cable, jumper phase A of the connector to the shield.

At the system unit end of the cable, measure the resistance between phase A and the shield.  
If the resistance is more than 200 ohms, phase A and phase B are reversed. Remove the jumper and repair the cable.

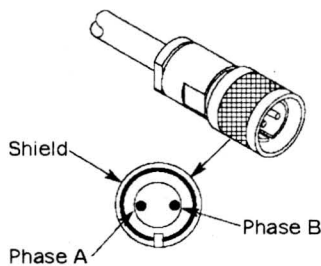



---

## Section 8. Disk Procedures

- 801 Multiple CAXX SRCs (5363 II and IV only) 8-2
- 802 Using Disk Drive Problem Determination 8-3
- 803 Analyzing Disk Drive ERAP 8-4
- 804 Disk Drive Analyze Procedure 8-5
- 805 Disk Drive Isolation Procedure 8-7
- 814 Disk Drive Removal and Replacement 8-11
- 816 Disk Drive Logic Card Removal and Replacement 8-15

---

## 801 Multiple CAxx SRCs (5363 II and IV only)

If multiple CAxx SRCs appeared on the system console and the machine is a level II or IV system, swap the disk adapter cards in card locations A1A2 and A1C2.

Perform a normal IPL, see "320 Loading the SSP" on page 3-8.

- If the multiple CAxx SRCs are displayed again, go to "804 Disk Drive Analyze Procedure" on page 8-5.
- If an SRC indicates the card in location A1C2, or a processor check occurs, exchange the card in location A1C2.

---

## 802 Using Disk Drive Problem Determination

Go to "Procedure 121" on page 1-8.

## 803 Analyzing Disk Drive ERAP

### Example Error History Table for Disk Drive X

ERROR HISTORY TABLE FOR DISK DRIVE X																	
FROM: XX/XX/XX XX:XX:XX			TO: XX/XX/XX XX:XX:XX														
DATE	TIME	SRC	CMD	CMD	SENSE BYTES					PRESENT		START		RETRY			
YYMMDD	HHMMSS		CODE	MOD	SB	0	1	2	3	4	5	OP	SS	ADR	SS	ADR	CNT
.....HEX.....																	
XXXXXX	XXXXXX	XXXX	XX	XX	XX	XX	XX	XX	XX	XX	XX	XX	XXXXXX	XXXXXX	XX		
XXXXXX	XXXXXX	XXXX	XX	XX	XX	XX	XX	XX	XX	XX	XX	XX	XXXXXX	XXXXXX	XX		
XXXXXX	XXXXXX	XXXX	XX	XX	XX	XX	XX	XX	XX	XX	XX	XX	XXXXXX	XXXXXX	XX		
XXXXXX	XXXXXX	193C	B2	00	10	XX	XX	XX	XX	XX	XX	XX	XXXXXX	XXXXXX	XX		

The following information shows how to use the CMD CODE field to identify the disk drive selected and the command being executed when the error occurred.

### CMD CODE

The following information is contained in the command code field:

- The left character indicates the disk drive:
  - A = Drive A
  - B = Drive B
  - C = Drive C
  - D = Drive D
- The right character indicates the command being executed:
  - 1 = Read
  - 2 = Write
  - 3 = Scan

### SB

Use the information in the sense byte summary field to determine the type of error found.

- 80 Permanent ECC error
- 40 No record found error
- 20 Reserved
- 10 Temporary error
- 08 Hardware error
- 04 Reserved
- 02 ECC field inverted
- 01 Temporary error, corrected by ECC

**Note:** A disk utility is available to analyze intermittent disk problems. For a system with a maximum of two drives the disk utility is on diskette 60 (IBM part 6374373). For a system with a maximum of 4 disk drives, the disk utility is on diskette 61.

## 804 Disk Drive Analyze Procedure

The following table shows what combinations of disk drives can be used.

**Note:** Use the part numbers to determine which size disk drives you have.

Part Number	Disk Drive
69X6909	65 Mb
92X7320	105 Mb
21F4250	314 Mb

Disk Drive	Mb	Part Number in A1C2	Part Number in A1A2	Comment
A	65 Mb	92X3224		Drive B could be 65 Mb or 105 Mb
A	65 Mb	92X7256		Drive B could be 65 Mb or 105 Mb
A	105 Mb	92X3224		Drive B could be 65 Mb or 105 Mb
A	105 Mb	92X7256		Drive B could be 65 Mb, 105 Mb, or 314 Mb
A	314 Mb	92X7256		Drive B could be 105 Mb or 314 Mb
B	65 Mb	92X3224		Drive A could be 65 Mb or 105 Mb
B	65 Mb	92X7256		Drive A could be 65 Mb or 105 Mb
B	105 Mb	92X3224		Drive A could be 65 Mb or 105 Mb
B	105 Mb	92X7256		Drive A could be 65 Mb, 105 Mb, or 314 Mb
B	314 Mb	92X7256		Drive A could be a 105 Mb or 314 Mb
C	65 Mb		92X7256	Drive D could be 65 Mb or 105 Mb
C	105 Mb		92X7256	Drive D could be 65 Mb, 105 Mb, or 314 Mb
C	314 Mb		92X7256	Drive D could be 105 Mb or 314 Mb
D	65 Mb		92X7256	Drive C could be 65 Mb or 105 Mb
D	105 Mb		92X7256	Drive C could be 65 Mb, 105 Mb, or 314 Mb
D	314 Mb		92X7256	Drive C could be 105 Mb or 314 Mb

This procedure is used to analyze permanent and intermittent disk problems, or to identify the failing disk drive.

1. If the machine is a 5363 I, II, III, or IV, load the system from diskette 61.

If the machine is a 5363, load the system from diskette 60.

- a. Select function 3 (IPL Diagnostic Diskette).
- b. Enter 0000.
- c. Press the Start Function key.

2. If a processor check occurred, go to "805 Disk Drive Isolation Procedure" on page 8-7. If an SRC, indicating a disk drive failure, is displayed on the system console before the DCP main menu appears, record the SRC. Press the Enter key to obtain the DCP main menu.
3. Select option 1, Disk Analyze.
4. All disk drives that are installed should be shown on the screen with the correct size. If an installed drive is shown as "not installed," or the size shown is not correct, see "805 Disk Drive Isolation Procedure" on page 8-7.
5. Select the option to analyze the drive indicated by either the original SRC, or the SRC recorded in step 2.
6. If an error occurs during the disk analyze procedure, follow the instructions displayed on the system console. If the problem continues, the disk drive indicated by the disk analyze procedure is defective and should be exchanged. The logic card may be exchanged ("816 Disk Drive Logic Card Removal and Replacement" on page 8-15) before exchanging the drive.
7. If it took more than 40 minutes (90 minutes for a 314 Mb drive) to run analysis on one drive, that drive is defective and should be exchanged. The logic card may be exchanged ("816 Disk Drive Logic Card Removal and Replacement" on page 8-15) before exchanging the drive.
8. If the values from the disk analyze procedure exceed the ranges in the following table, ensure that the customer's data is backed up, then initialize the defective drive.

If the values from the disk analyze procedure do not exceed the ranges in the following table, this procedure is complete.

**Expected Range by type of disk drive**

Type of Error	65 Mb	105 Mb	314 Mb
Alternate sector(s) assigned	0 to 47	0 to 47	0 to 47
Temporary (2 to 16 retries)	0 to 11	0 to 17	0 to 51
Sys recoverable (17 to 56 retries)	0 to 3	0 to 4	0 to 12
Permanent	0	0	0

9. Run the disk analyze utility on the initialized drive.
10. If the results still indicate a defective drive, exchange the drive. ("814 Disk Drive Removal and Replacement" on page 8-11).

## 805 Disk Drive Isolation Procedure

Do not continue with this procedure unless you have performed "804 Disk Drive Analyze Procedure" on page 8-5.

**Note:** Use the part number to determine which size disk drive you have.

Part Number	Disk Drive
69X6909	65 Mb
92X7320	105 Mb
21F4250	314 Mb

1. Measure the disk drive voltages and compare with the chart in procedure "435 DC Voltage Distribution" on page 4-11.
2. If the specified voltages are not present, exchange the failing power supply.
3. If the specified voltages are present, continue with the next step.
4. If the system is a 5363 II or IV and has four drives installed, go to step 22 on page 8-9. If not, continue with the next step.
5. If the system is a 5363 II or IV and has three drives installed, go to step 10. If not, continue with the next step.
6. If an SRC, indicating a disk drive A or B failure, is displayed, or disk drive A and B are shown as "not installed," or the size shown is not correct, unplug the cables to disk drive B.
7. If the machine is a 5363 I, II, III, or IV, load the system from diskette 61.  
If the machine is a 5363, load the system from diskette 60.
  - a. Select function 3 (IPL Diagnostic Diskette).
  - b. Enter 0000.
  - c. Press the Start Function key.
  - d. Select Option 1, Disk Analyze.
8. If an SRC, indicating a disk drive failure, is displayed, or disk drive A is shown as "not installed," or the size shown is not correct, disk drive A is defective and should be exchanged. The logic card may be exchanged ("816 Disk Drive Logic Card Removal and Replacement" on page 8-15) before exchanging the drive.
9. If disk drive A is shown as the correct size, disk drive B is defective and should be exchanged. The logic card may be exchanged ("816 Disk Drive Logic Card Removal and Replacement" on page 8-15) before exchanging the drive.
10. If an SRC indicating a disk drive failure is displayed, a disk drive is shown as "not installed," or the size shown is not correct, use the first failing drive indicated and the following chart to determine which step to go to.

Disk Drive	Step
A	11 on page 8-8
B	14 on page 8-8
C	18 on page 8-8

11. Unplug the cables from disk drives B and C.
12. If the machine is a 5363 I, II, III, or IV, load the system from diskette 61.  
If the machine is a 5363, load the system from diskette 60.
  - a. Select function 3 (IPL Diagnostic Diskette).
  - b. Enter 0000.
  - c. Press the Start Function key.
  - d. Select Option 1, Disk Analyze.
13. If an SRC indicating a disk drive failure is displayed, disk drive A is defective and should be exchanged. The logic card may be exchanged ("816 Disk Drive Logic Card Removal and Replacement" on page 8-15) before exchanging the drive.
14. If disk drive A is shown as the correct size, attach the cables to disk drive B if removed earlier. Unplug the cables to disk drive C if not removed earlier.
15. If the machine is a 5363 I, II, III, or IV, load the system from diskette 61.  
If the machine is a 5363, load the system from diskette 60.
  - a. Select function 3 (IPL Diagnostic Diskette).
  - b. Enter 0000.
  - c. Press the Start Function key.
  - d. Select Option 1, Disk Analyze.
16. If an SRC, indicating a disk drive failure, is displayed, or disk drive B is shown as "not installed," or is the size shown is not correct, disk drive B is defective and should be exchanged. The logic card may be exchanged ("816 Disk Drive Logic Card Removal and Replacement" on page 8-15) before exchanging the drive.
17. If disk drive B is shown as the correct size, disk drive C is defective and must be exchanged. The logic card may be exchanged ("816 Disk Drive Logic Card Removal and Replacement" on page 8-15) before exchanging the drive.
18. If an SRC, indicating a disk drive failure, is displayed, or disk drive C is shown as "not installed," or the size shown is not correct, disk drive C may be defective. Label the disk drives in locations B and C and swap disk drives B and C. Remove the terminating resistor from disk drive C and place it on the back of disk drive B.
19. If the machine is a 5363 I, II, III, or IV, load the system from diskette 61.  
If the machine is a 5363, load the system from diskette 60.
  - a. Select function 3 (IPL Diagnostic Diskette).
  - b. Enter 0000.
  - c. Press the Start Function key.
  - d. Select Option 1, Disk Analyze.
20. If an SRC indicating a disk drive failure is displayed, or disk drive C is shown as "not installed," or the size shown is not correct, the disk drive cables to disk drives C and D are defective and must be exchanged.
21. If an SRC indicating a disk drive failure is displayed, or disk drive B is shown as "not installed," or the size shown is not correct, drives B and C must be returned to the locations labeled in step 18 and the terminating resistor must be removed from disk drive B and placed on the back of disk drive C. Exchange the disk drive in location C. The logic card may be exchanged ("816 Disk Drive Logic Card Removal and Replacement" on page 8-15) before exchanging the drive.

22. If an SRC indicating a disk drive failure is displayed, a disk drive is shown as "not installed," or the size shown is not correct, use the first failing drive indicated and the chart below to determine which step to go to.

Disk Drive	Step
A	23
B	26
C	29
D	31

23. Unplug the cables to disk drives B, C, and D.
24. If the machine is a 5363 I, II, III, or IV, load the system from diskette 61.  
If the machine is a 5363, load the system from diskette 60.
- Select function 3 (IPL Diagnostic Diskette).
  - Enter 0000.
  - Press the Start Function key.
  - Select Option 1, Disk Analyze.
25. If an SRC, indicating a disk drive failure, is displayed, or disk drive A is shown as "not installed," or the size shown is not correct, disk drive A is defective and should be exchanged. The logic card may be exchanged ("816 Disk Drive Logic Card Removal and Replacement" on page 8-15) before exchanging the drive.
26. If disk drive A is shown as the correct size, attach the cables to disk drive B if removed earlier. Unplug the cables to disk drives C and D if not removed earlier.
27. If the machine is a 5363 I, II, III, or IV, load the system from diskette 61.  
If the machine is a 5363, load the system from diskette 60.
- Select function 3 (IPL Diagnostic Diskette).
  - Enter 0000.
  - Press the Start Function key.
  - Select Option 1, Disk Analyze.
28. If an SRC, indicating a disk drive failure, is displayed, or disk drive B is shown as "not installed," or the size shown is not correct, disk drive B is defective and should be exchanged. The logic card may be exchanged ("816 Disk Drive Logic Card Removal and Replacement" on page 8-15) before exchanging the drive.
29. If disk drive B is shown as the correct size, attach the cables to disk drive C if removed earlier. Unplug the cables to disk drive D if not removed earlier.
30. If the machine is a 5363 I, II, III, or IV, load the system from diskette 61.  
If the machine is a 5363, load the system from diskette 60.
- Select function 3 (IPL Diagnostic Diskette).
  - Enter 0000.
  - Press the Start Function key.
  - Select Option 1, Disk Analyze.
31. If disk drive C is shown as the correct size, disk drive D is defective and must be exchanged. The logic card may be exchanged ("816 Disk Drive Logic Card Removal and Replacement" on page 8-15) before exchanging the drive.

32. If disk drive C is shown as "not installed," or the size shown is not correct, disk drive C may be defective. Label the disk drives in locations C and D and swap disk drives C and D. Remove the terminating resistor from disk drive C and place it on the back of disk drive D.
33. If the machine is a 5363 I, II, III, or IV, load the system from diskette 61.  
If the machine is a 5363, load the system from diskette 60.
  - a. Select function 3 (IPL Diagnostic Diskette).
  - b. Enter 0000.
  - c. Press the Start Function key.
  - d. Select Option 1, Disk Analyze.
34. If the disk drive in location C is shown as the correct size, the disk drive originally in location C is defective and must be exchanged. The logic card may be exchanged ("816 Disk Drive Logic Card Removal and Replacement" on page 8-15) before exchanging the drive.
35. If the disk drive in location C is shown as "not installed" or the size shown is not correct, suspect the following FRUs:

%	FRU
90	A1 Board
10	J28/J29 interface cables

36. Drives C and D must be returned to the locations labeled in step 32 and the terminating resistor must be removed from disk drive D and placed on the back of disk drive C.

---

## 814 Disk Drive Removal and Replacement

### Disk Drive Removal

1. Power off the 5363.
2. Remove the covers ("305 Cover Removal" on page 3-2).

**Note:** Use the part number to determine which disk drive you have.

Part Number	Disk Drive
69X6909	65 Mb
92X7320	105 Mb
21F4250	314 Mb

3. The part number is located on the front panel of the disk drive.
4. Remove the two retainer brackets (four screws).
5. Slide the disk drive slightly toward the front of the 5363.
6. Disconnect the cables from the rear of the disk drive. (One power cable and two signal cables each drive.)
7. Slide the disk drive out of the 5363 frame.

**Notes:**

- a. "816 Disk Drive Logic Card Removal and Replacement" on page 8-15 may be used to exchange the logic card on the disk drive. If installing a new logic card does not correct the problem, the disk drive must be exchanged. If you do not want to exchange the logic card, continue with this procedure.
  - b. Before you install a new disk drive, ensure that the switches are set correctly.
  - c. Before you install a new disk drive A or C, ensure that the terminating resistor is on the back of the disk drive.
  - d. Before you install a new disk drive B or D, remove the terminating resistor from the back of the disk drive.
  - e. If you installed a new disk drive, go to "Disk Drive Initialization Procedure" on page 8-14.
8. Install the disk drive by doing the previous steps in reverse order.

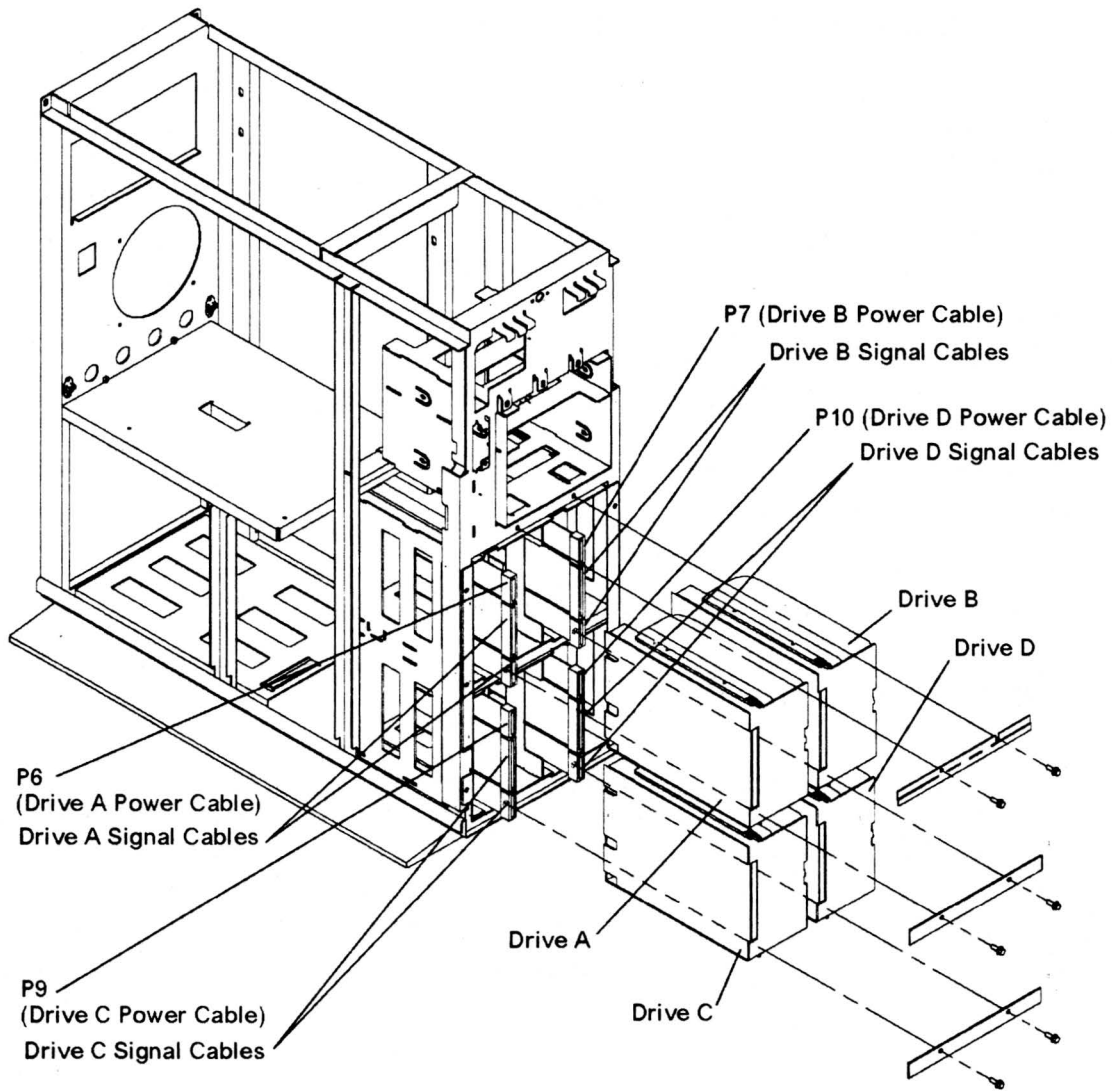

R36B130-4

# 65 Mb or 105 Mb Disk Drive

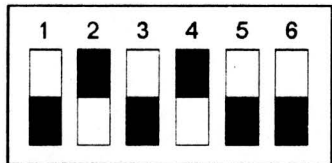
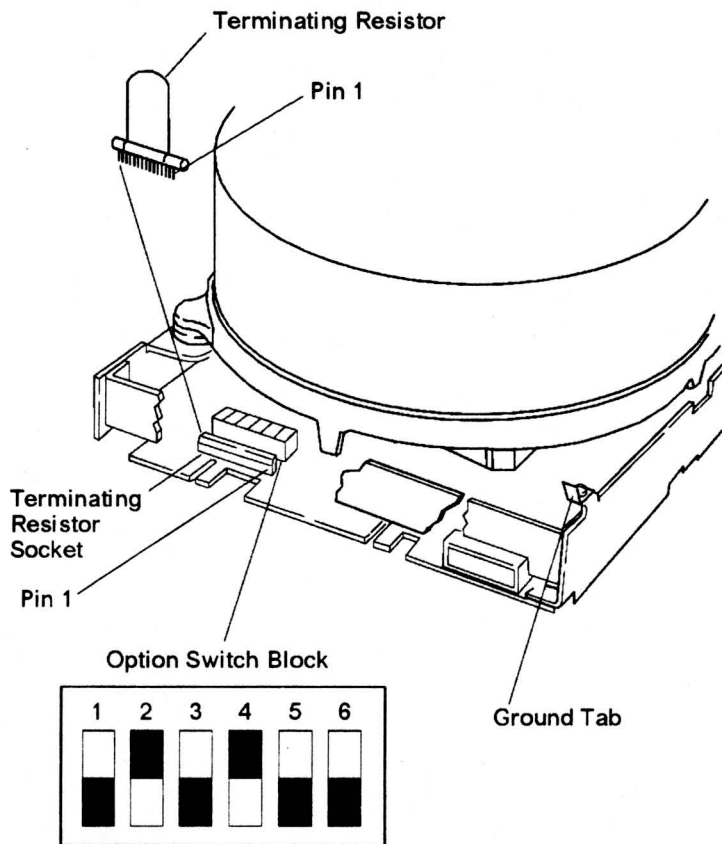

Dark area indicates where switch is pushed down.

R36B155-3

## 314 Mb Disk Drive

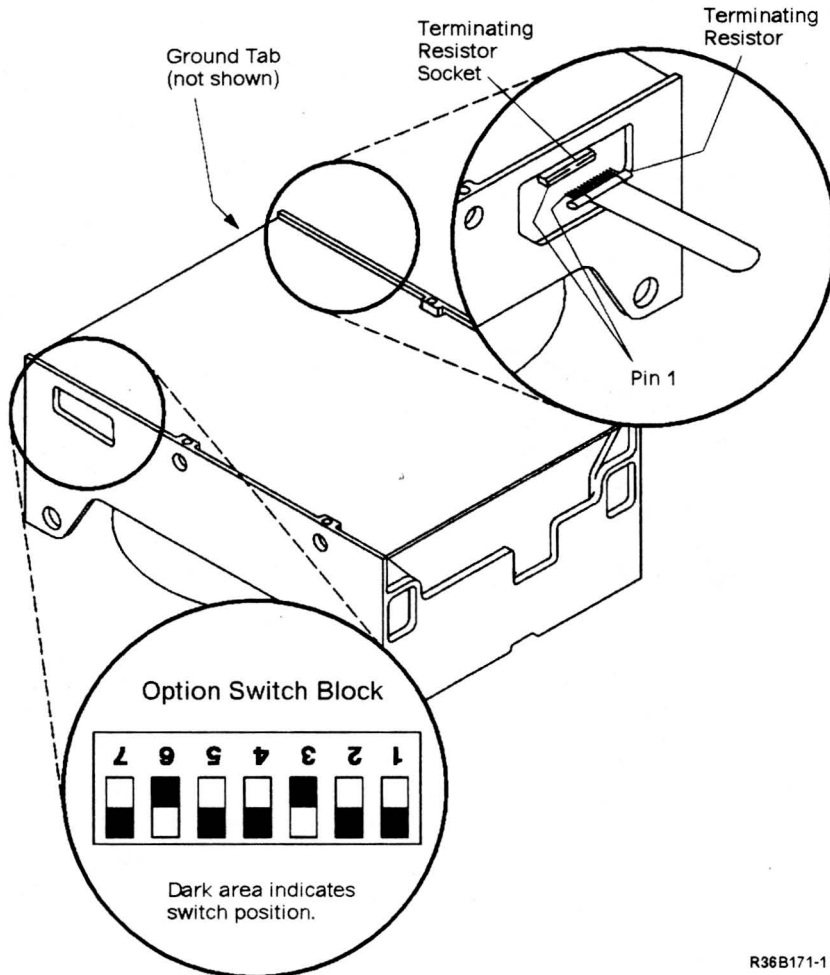

## Disk Drive Initialization Procedure

This procedure is used to initialize new disk drives after they are installed in the 5363 system.

1. Load the system from diskette 61:
  - a. Select function 3 (IPL Diagnostic Diskette).
  - b. Enter 22FF.
  - c. Press the Start Function key.
2. Select the option to initialize the new disk drive.
3. Follow the prompts.
4. After completion of the initialization procedure, do the following:
  - a. To perform an Auto Configuration, go to "321 Auto Configuring the System" on page 3-8.
  - b. To perform an SSP reload, go to "322 Reloading the SSP Diskettes" on page 3-9.
5. This procedure is complete.

---

## 816 Disk Drive Logic Card Removal and Replacement

This procedure may be used to exchange the logic card on the disk drive. If this does not correct the problem, the disk drive must be exchanged.

1. The disk drive must first be removed from the 5363 machine, see "814 Disk Drive Removal and Replacement" on page 8-11.

**Note:** The part number of the logic card is different for each size drive.

<b>Part Number</b>	<b>Logic Card</b>
6370793	65 Mb logic card
6370951	105 Mb logic card
21F4580	314 Mb logic card

2. Place the disk drive on a table with the logic card facing up.
3. Remove the screws that hold the logic card.

**Notes:**

- a. Some disk drives use size 10 TORX screws. If needed, order part 16F1617, (a bit used with screwdriver part 9900712).
  - b. The 65 Mb and 105 Mb logic cards are held by four screws. The 314 Mb logic card is held by five screws.
4. If the logic card has a protective covering, it must be removed and discarded.

**Warning:** All cables connected to the logic card are easily damaged from careless handling. Avoid pulling or stretching the cables.

5. Gently lift the disk logic card to allow access to the cables connecting the disk drive to the logic card.

**Notes:**

- a. There are 3 cables connected to the logic card on the 65 Mb disk drive.
  - b. There are 4 cables connected to the logic card on the 105 Mb disk drive.
  - c. There are 2 cables connected to the logic card on the 314 Mb disk drive.
6. Carefully disconnect the cables from the logic card.
  7. Set the switches on the logic card being installed the same as switches on the logic card being removed from the drive. If the logic card being removed does not have a terminating resistor, remove the terminating resistor from the logic card being installed.
  8. Install the new logic card, connect the cables in the following order:

**65 Mb or 105 Mb Disk Drive**

- a. 24-pin connector
- b. 2-pin connector
- c. 12-pin connector
- d. 3-pin connector (105 Mb disk drive only)

**314 Mb Disk Drive**

- a. 30-pin connector
- b. 8-pin connector

9. The screws removed in step 3 must be put in place and tightened.
10. To reinstall the disk drive, go to step 8 on page 8-11.



---

## Section 9. Communications Procedures

- 910 Isolating Communications Problems 9-2
- 915 Serial/Parallel Adapter Jumper Setup 9-3
- 917 Isolating Communications Cable Problems 9-3
- 920 Communications Diagnostic Tests 9-4
- 930 Displaying Communications Configuration Status 9-5
- 935 Displaying Communications Line Status 9-6
- 950 Running the BSC On line Test 9-8
- 955 Running the SDLC On line Test 9-9
- 980 SDLC and BSC Adapter EIA RS-232-C Signal Pins 9-10
- 982 Serial Parallel/Adapter, Serial Port EIA RS232-C Signal Pins (Used for Asynchronous Communications) 9-11
- 984 IBM Realtime Interface Co-Processor Jumper and Switch Setup 9-12
- 985 IBM Realtime Interface Co-Processor V.35 Electrical Interface Signal Pins 9-13
- 986 IBM Realtime Interface Co-Processor RS-232-C Electrical Interface Signal Pins 9-14
- 987 Electrical Interface Board Removal and Replacement 9-15
- 988 Binary Synchronous Communications Jumper Setup 9-17

---

## 910 Isolating Communications Problems

This procedure uses SSP procedures (for example, COMMTEST) to display status and diagnose communications problems. Use this procedure to diagnose communications problems when no SRCs are specified or when the SRC does not isolate a specific FRU or area of the communications network.

1. If a switched network is being used, dial another number to see if the failure is at the remote location or in the 5363 communications hardware.
2. Type COMMTEST on the SSP command line on the system console and press the Enter key. Follow the displayed instructions.

The COMMTEST checks the hardware logic of the communications card in the 5363.

If the COMMTEST does not isolate the failure, continue with the next step.

3. Do one of the following:
  - a. For systems using a BSC card or an IBM Realtime Interface Co-processor to run BSC:

Type BSCTEST on the SSP command line and press the Enter key. When the prompt indicates to insert a diskette, insert diskette 61. Follow the prompts.

The BSC on line test checks the modem, the line, and the functions of the BSC card in 5363.
  - b. For systems using a SDLC card or an IBM Realtime Interface Co-Processor to run SDLC:

Type SDLCTEST on the SSP command line and press the Enter key. When the prompt indicates to insert a diskette, insert diskette 61. Follow the prompts.

The SDLC on line test checks the modem, the line, and the functions of the SDLC card in 5363.
4. If the failure is still present, display the communication line status to determine if data is being transmitted or received, and that the line status is correct. See "935 Displaying Communications Line Status" on page 9-6.

---

## 915 Serial/Parallel Adapter Jumper Setup

### Serial/Parallel Adapter (Used for ASYNC Communications)

The Serial/Parallel adapter comes set to be used as line 2. If this is the desired setting, the card is ready to install in the machine.

If the adapter is being used as line 1, remove the module J1 and install it as shown below. To remove the module, insert a small flat-blade screwdriver under the module and lift up.

The card is now ready to be installed in the machine.

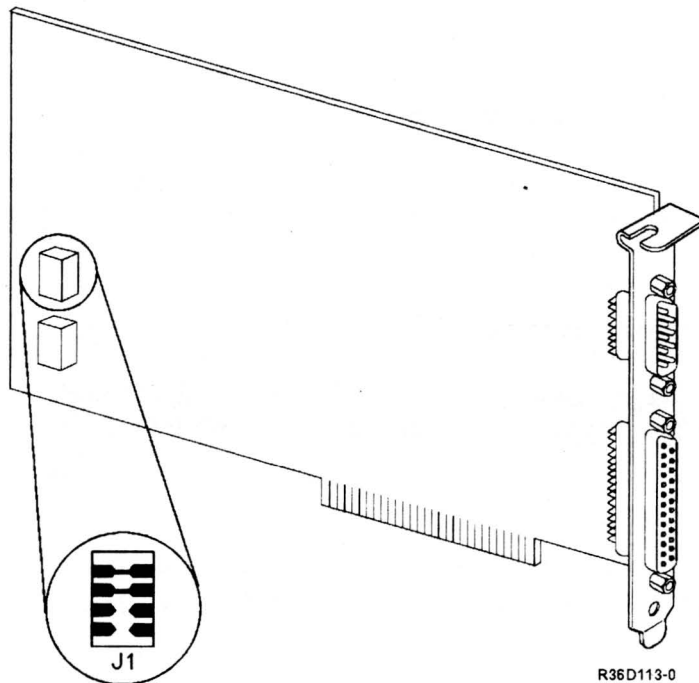

---

## 917 Isolating Communications Cable Problems

To isolate problems in external communications cables, use the following procedures:

- "980 SDLC and BSC Adapter EIA RS-232-C Signal Pins" on page 9-10.

---

## 920 Communications Diagnostic Tests

This procedure uses SSP procedures (for example, PROBLEM) to diagnose communications problems. Diagnostic tests for data communications attempt to locate problems with internal and some external data communications interfaces. There are four types of diagnostic tests for data communications:

- Diagnostic tests during IPL
- Diagnostic tests during on line problem determination
- Diagnostic tests during concurrent maintenance
- Diagnostic tests during customer setup (CSU)

### Diagnostic Tests During IPL

Diagnostic tests during IPL test the communications hardware.

### Diagnostic Tests During On line Problem Determination

Diagnostic tests during on line problem determination (PROBLEM) test the communications hardware, microcode, and local and remote work stations. See the manual *System Problem Determination – 5363* for procedures.

### Diagnostic Tests During Concurrent Maintenance

Concurrent diagnostic tests are run under SSP while the system is operating on other jobs. Only the line being tested must be assigned to the test when these tests are run. The other lines can be used for system data communication.

Concurrent diagnostic tests include:

- **SDLCTEST:** The SDLC on line test verifies correct operation of the communications link between two systems, or between the system and attached SDLC devices. See “955 Running the SDLC On line Test” on page 9-9.
- **BSCTEST:** The BSC on line test verifies correct operation of the communications link between two systems, or between the system and attached BSC devices. See “950 Running the BSC On line Test” on page 9-8.
- **STATEST:** The station test verifies correct operation of the communications link between the system and the remote work stations.

**Note:** When STATEST is started to test a switched line, the primary station (host) waits for a call from the secondary station (remote) to start the station test. STATEST is run on a line that is varied on and runs concurrent with other traffic on the line.

- **COMMTEST:** The communications concurrent diagnostic test has the following option:
  - Basic communications diagnostic test: This test checks out the communications hardware and external cables where possible. All lines must be varied off.

### Diagnostic Tests During Customer Setup

Diagnostic tests during customer setup (CSU) test the communications hardware; data is wrapped through the line adapters.

---

## 930 Displaying Communications Configuration Status

Some communications configuration data can be changed by the SETCOMM procedure or by the ALTERCOM procedure under SSP. These changes can affect the way communications jobs run. You can verify the configuration status of each communications line using the STATUS COMCNFIG and STATUS COMM procedures.

The SETCOMM and ALTERCOM procedures are described as follows:

- **SETCOMM:** The SETCOMM procedure under SSP changes some communications parameters in the system configuration record. An initial program load (IPL) must be performed before the changes take effect. The changes are permanent.

You can use the STATUS COMCNFIG (D H) command to display the present settings.

- **ALTERCOM:** The ALTERCOM procedure under SSP changes some items associated with batch BSC, SDLC, or a communications line. ALTERCOM changes information only for the display station at which it is run. If ALTERCOM is run while an SSP-ICF (interactive communications feature) subsystem or batch BSC job is running, it will have no effect on the job that is running. Changes made using ALTERCOM remain in effect until the ALTERCOM procedure is run again, or until the SETCOMM procedure is run.

You can use the STATUS COMM (D C) command to display the present settings.

Use the help menus or see the *System Reference* manual for additional information on these procedures.

---

## 935 Displaying Communications Line Status

Communications status for any line can be displayed at any time.

1. Ensure that the Security switch is in the Service position.
2. Select function A (Communications Line Status). A 1 appears in the low-order position of the 4-character display.
3. Select a communications line, using the low-order Input key.
4. Press the Start Function key. The selected line status is displayed in the 4-character display.

Use the communications template found with this manual to decode the Communications Line Status.

5. To select another communications line:
  - a. If the Output Display light is on, press the Display key. The selected line number is displayed.
  - b. Select a communications line, using the low-order Input key.
  - c. Press the Display key again. The Output Display light is activated and the selected line status is displayed in the 4-character display.

# Communications Line Status Template

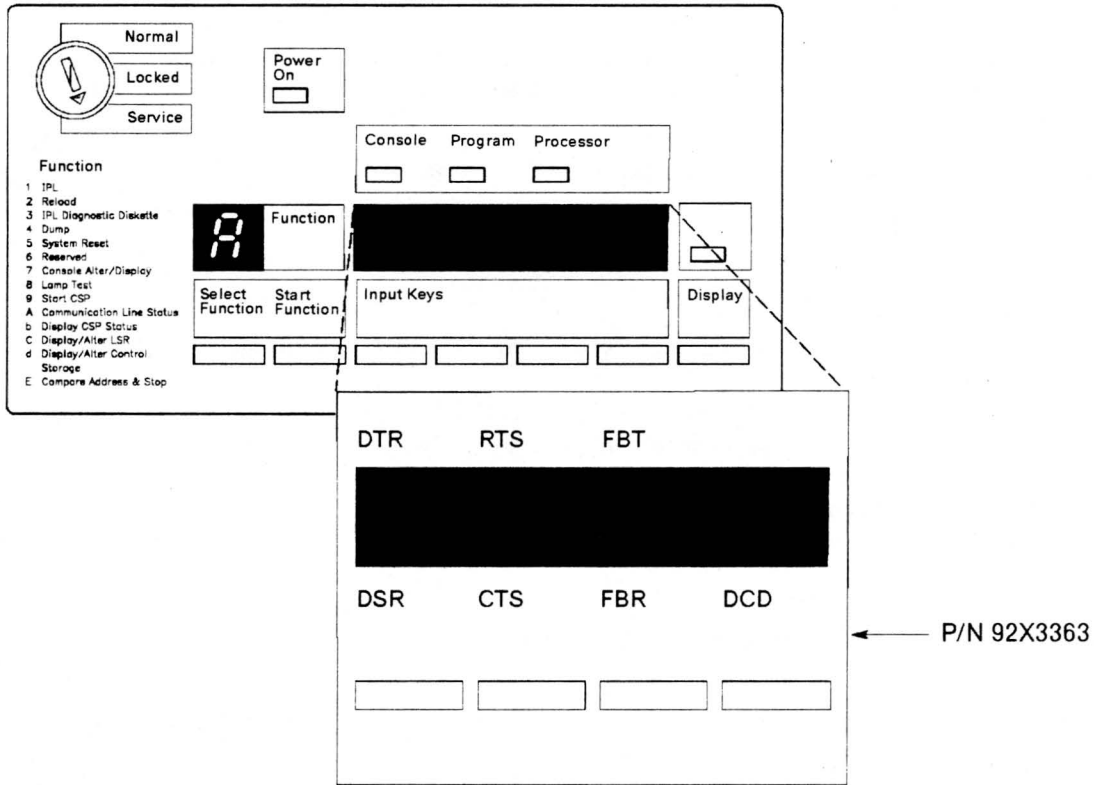

R36B131-3

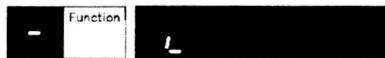

R36B132-0

## Legend for Line Status:

### Term Meaning

- CTS Clear to send
- DSR Data set ready
- DTR Data terminal ready
- FBR Frame Block Received
- RTS Request to send
- FBT Frame Block Transmit
- DCD Data Carrier Detect

---

## 950 Running the BSC On line Test

The BSC on line test verifies correct operation of the communications link between two systems, or between the system and attached BSC devices. To run the BSC on line test, a similar support program must be started at the remote location.

1. Key in BSCTEST on the SSP command line and press the Enter key.
2. Insert diskette 61, when prompted for a diskette.
3. Select:
  - a. A line number to be tested.
  - b. REQUESTOR (to start the BSC test to another system) or RESPONDER (to answer the BSC test request from another system).
  - c. The data coding the customer has been using (ASCII or EBCDIC).
  - d. YES to review or change the communications configuration. Always attempt to run the test with the present configuration before making any changes unless you are attempting to run to a system or device that the customer was not using.
  - e. For switched line configurations, you may be prompted for security information (a customer option).
4. Select the test to be run.
5. Select the number of times the test should be run. You should run two or more tests at least 10 times each.
6. Analyze the results. If the test ends with no errors, the communications link is operating correctly now.

---

## 955 Running the SDLC On line Test

The SDLC on line test verifies correct operation of the communications link between two systems, or between the system and attached SDLC devices (for example, IBM 5251 Model 12 or IBM 5294 controllers). To run the SDLC on line test to another system, a similar support program must be started at the remote location. To run the SDLC on line test to a remote work station, you must use the VARY command. See "329 Summary of Useful SSP Procedures" on page 3-12 to change the selected line to off-line.

1. Key in SDLCTEST on the SSP command line and press the Enter key.
2. Insert diskette 61, when prompted for a diskette.
3. Select:
  - a. A line number to be tested.
  - b. REQUESTOR (to start the SDLC test to another system or device) or RESPONDER (to answer the SDLC test request from another system).
  - c. YES to review or change the communications configuration. Always attempt to run the test with the present configuration before making any changes unless you are attempting to run to a system or device that the customer was not using. ALTERCOM changes the configuration only for the display station at which it is run. If configuration is correct and diagnostics run at the system console, but the customer job fails when it is run from another display station, repeat step 3 at that display station.
  - d. The hexadecimal address of the remote system, controller, or device to be tested.

**Note:** If the network is a point-to-point network, you can use hex FF as the address. If the network is a multipoint network, you must obtain the correct address from the customer.

4. Select the test to be run.
5. Select the number of times the test should be run. You should run two or more of the first six tests at least 10 times each.
6. Analyze the results. If the test ends with no errors, the communications link is operating correctly now.

# 980 SDLC and BSC Adapter EIA RS-232-C Signal Pins

Signal Name	Signal Pins		Signals Wrapped
	System End	Cable End	
Outer cable shield	N.C.	1	
Transmit data space (TDS)	2	2	>
Receive data space (RDS)	3	3	<
Request to send (RTS)	4	4	>
Clear to send (CTS)	5	5	<
Data carrier detect (DCD)	8	8	<
Data set ready (DSR)	6	6	<
Data terminal ready (DTR)	20	20	>
Signal ground (GND)	7	7	
Select standby (SNBU)	11	11	>
Ring indicate (RI)	22	22	<
Receive clock (RX)	17	17	<
Transmit clock (TX)	15	15	<
Rate select (SELECT)	23	23	>
Test control (WRAP)	18	18	>
Test Indicate (TI)	25	25	>

System End

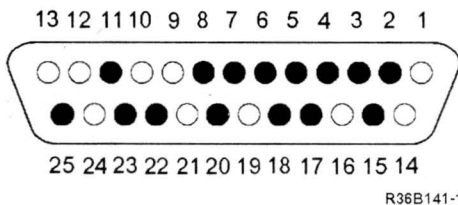

Cable End

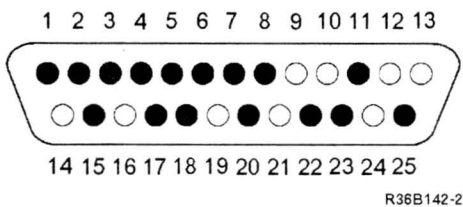

## 982 Serial Parallel/Adapter, Serial Port EIA RS232-C Signal Pins (Used for Asynchronous Communications)

Signal Name	Signal Pins		Signals Wrapped
	System End	Cable End	
Outer cable shield	N.C.	1	
Data carrier detect (DCD)	1	8	< ┌
Request to send (RTS)	7	4	> ┌
Clear to send (CTS)	8	5	< ┌
Receive data (RDS)	2	3	< ┌
Transmit data (TDS)	3	2	> ┌
Data terminal ready (DTR)	4	20	> ┌
Data set ready (DSR)	6	6	< ┌
Signal ground (GND)	5	7	
Ring indicator (RI)	9	22	

System End

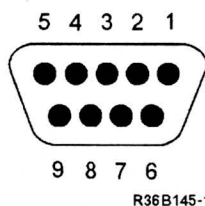

Cable End

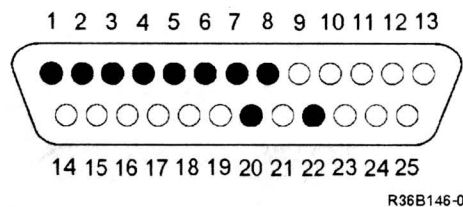

# 984 IBM Realtime Interface Co-Processor Jumper and Switch Setup

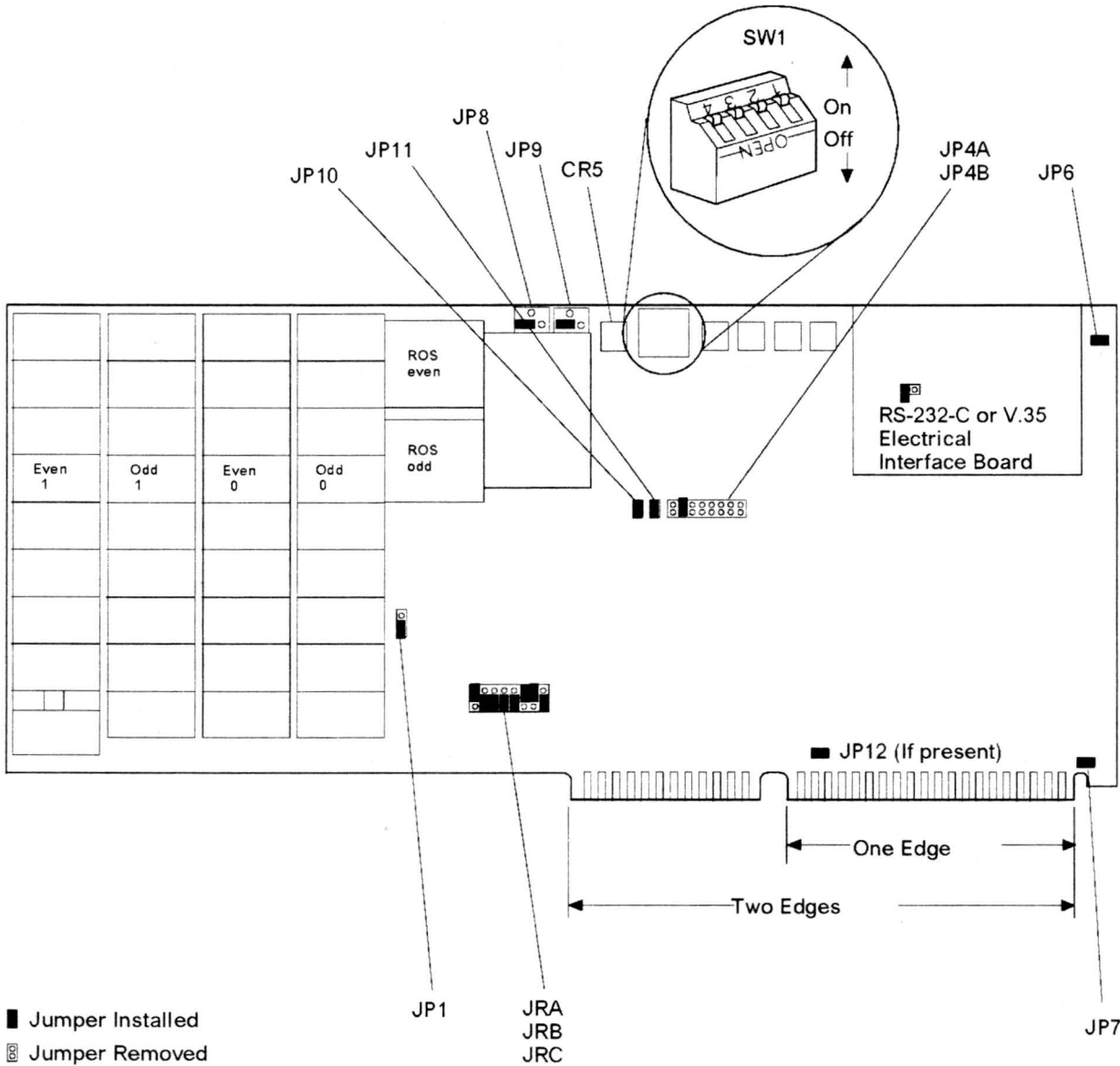

**Note:** If diskette 61 is IBM part number 6374384 or larger, the jumpers on JRA, JRB, JRC, JP4A, and JP4B must be set as shown below.



R36B154-3

# 985 IBM Realtime Interface Co-Processor V.35 Electrical Interface Signal Pins

Signal Name	Signal Pins		Signals Wrapped
	System End	Cable End	
Protective ground (FG)	1	B	
Transmit data B (TD-B)	2	S	>
Request to send (RTS)	3	C	>
Receive data B (RD-B)	4	T	<
Clear to send (CTS)	5	D	<
Data set ready (DSR)	6	E	
Data carrier detect (DCD)	7	F	<
Signal ground (GND)	8	B	
Transmit data A (TD-A)	9	P	>
Transmit clock A (TX-A)	10	Y	
Receive data A (RD-A)	11	R	<
Transmit clock B (TX-B)	12	AA	
Receive clock B (RX-B)	13	X	
Receive clock A (RX-A)	14	V	
Not connected	15	N.C.	

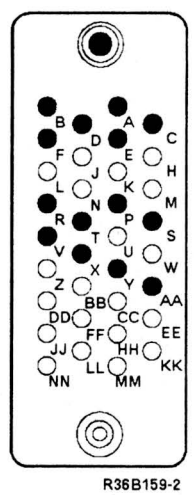
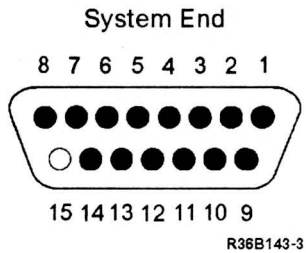

# 986 IBM Realtime Interface Co-Processor RS-232-C Electrical Interface Signal Pins

Signal Name	Signal Pins		Signals Wrapped
	System End	Cable End	
Transmit data (TDS)	2	2	>
Receive data (RDS)	4	3	<
Request to send (RTS)	3	4	>
Clear to send (CTS)	5	5	<
Data carrier detect (DCD)	7	8	<
Rate select (Select)	9	23	>
Ring indicator (RI)	11	22	<
Data set ready (DSR)	10	6	<
Data terminal ready (DTR)	12	20	>
Protective ground (FG)	N.C.	N.C.	
DTE clock	6	24	
Signal ground (GND)	8	7	
Transmit clock (TX)	13	15	
Receive clock (RX)	14	17	
Not connected	15	N.C.	

System End

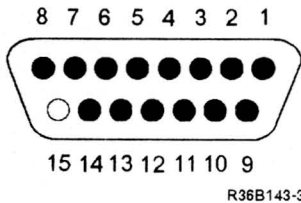

Cable End

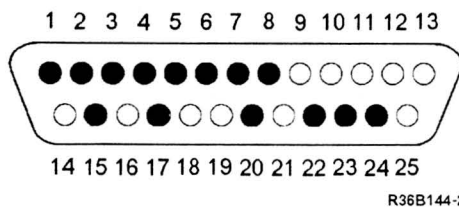

## 987 Electrical Interface Board Removal and Replacement

### Electrical Interface Board Installation

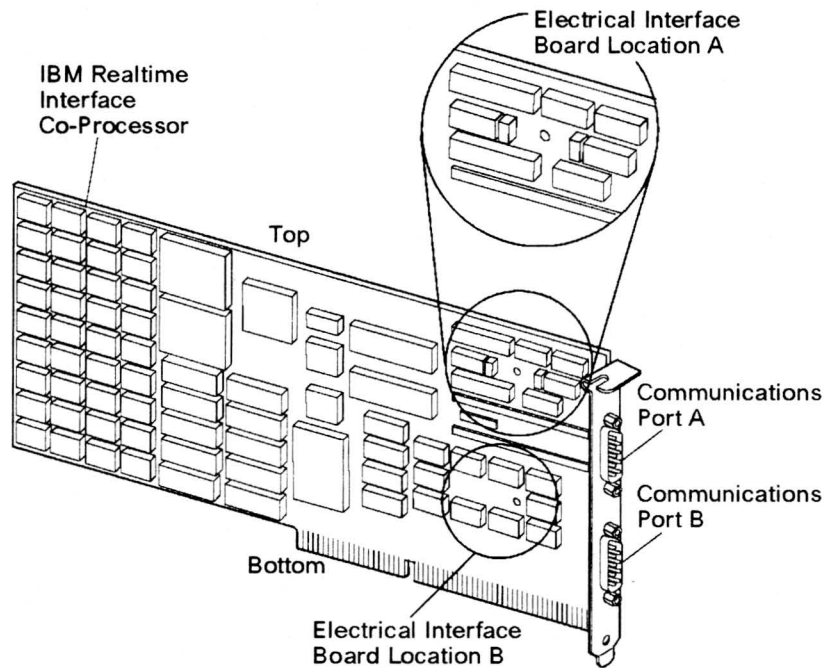

**Warning:** The pins on the electrical interface board are easily bent and must be accurately aligned with the connector before it is pressed into place. Ensure that the interface co-processor and the electrical interface board are correctly in position as shown before pressing them into place.

Substituting the plastic bolt and nuts with conductive materials (metal) can damage the device.

1. Remove the plastic nuts.
2. Remove the electrical interface board from the ARTIC card.
3. Remove the plastic nut and bolt from the electrical interface board.
4. Insert the plastic bolt through the hole located in the center of the electrical interface board.
5. Tighten the first plastic nut to the installed bolt as shown.
6. Align the pins on the electrical interface board with the sockets on the interface co-processor as shown. Use caution when working with the electrical interface board since the pins are very sharp.
7. Install the electrical interface board.
8. Inspect the alignment of the pins to ensure all pins are fully inserted into their corresponding sockets.
9. Finger-tighten the second plastic nut to the screw protruding through the selected hole in the interface co-processor. Do not over-tighten.

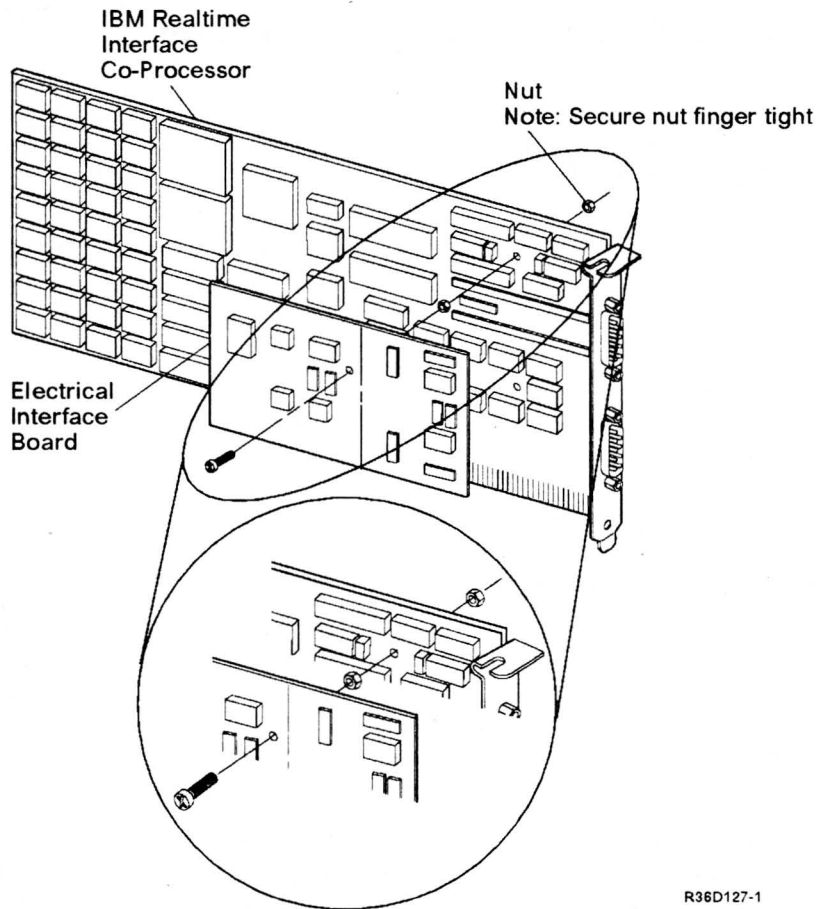

10. On the RS-232-C electrical interface board, set jumper J1 as shown.

**RS-232-C Jumper Positions**

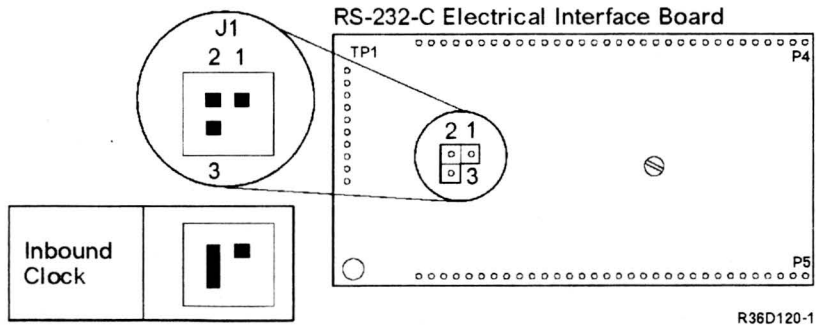

11. The card is now ready to be installed in the machine.

## 988 Binary Synchronous Communications Jumper Setup

Install the jumper on P3.

- Installing the jumper on pins 2 and 4 selects the *primary* BSC adapter mode.
- Installing the jumper on pins 1 and 3 selects the *alternate* BSC adapter mode.
- Connectors P1 and P2 must have jumpers as shown for correct operation of the adapter.

**Note:** If you also have an SDLC adapter installed, you must set P3 as *primary*.

- The card is now ready to be installed in the machine.

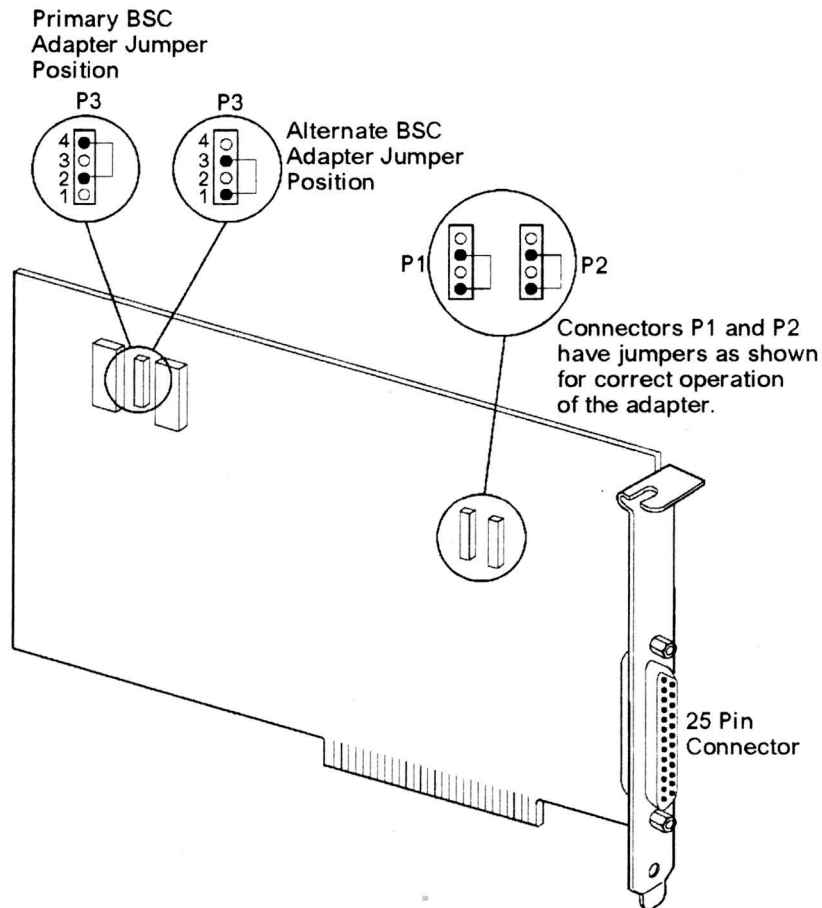

R36D112-2



---

## Section 10. Tape Drive Procedures

1010	53 Mb Tape Drive Removal	10-2
1012	120 Mb Tape Drive Removal	10-3

## 1010 53 Mb Tape Drive Removal

1. Power off the 5363 and disconnect the power cord at the customer power outlet and the 5363.
2. Remove the covers ("305 Cover Removal" on page 3-2).
3. Remove the four mounting screws (two on each side) from the tape drive.
4. Slide the tape drive slightly towards you to permit access to the cables.
5. Disconnect P11 power cable, signal cable and the ground wire.
6. Remove the tape drive by sliding the unit towards you until it is out of the 5363 frame.
7. Install the tape drive by doing the previous steps in reverse order.

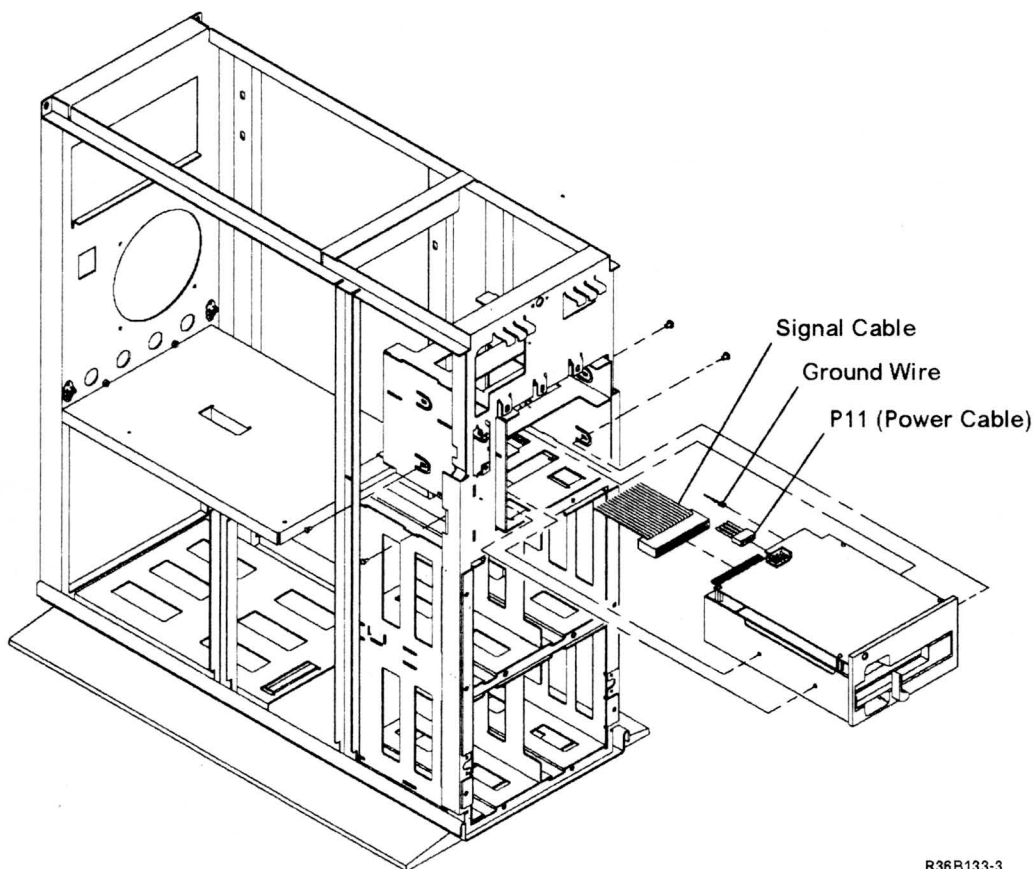

R36B133-3

## 1012 120 Mb Tape Drive Removal

1. Power off the 5363 and disconnect the power cord at the customer power outlet and the 5363.
2. Remove the covers ("305 Cover Removal" on page 3-2).
3. Remove the bezel.
4. Remove the four mounting screws (two on each side) from the tape drive.
5. Slide the tape drive slightly towards you to permit access to the cables.
6. Disconnect P11 power cable, signal cable and the ground wire.
7. Remove the tape drive by sliding the unit towards you until it is out of the 5363 frame.
8. Install the tape drive by doing the previous steps in reverse order.

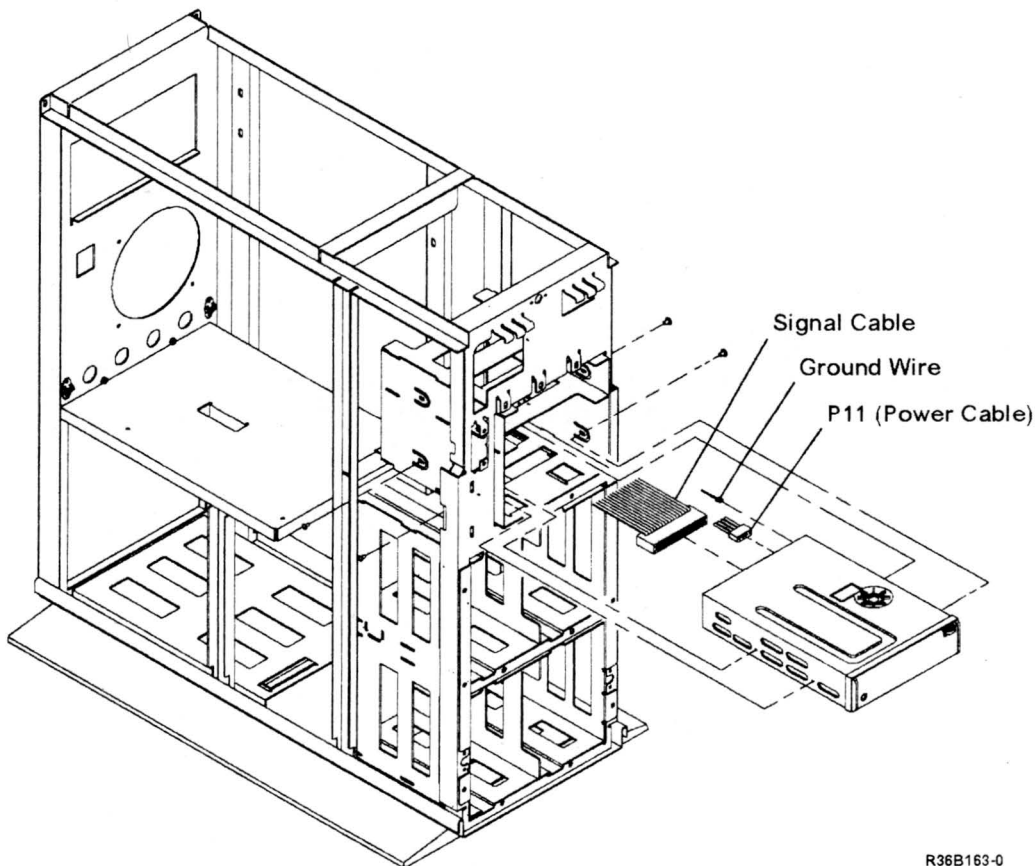

R36B163-0



---

## **Section 11. Local Area Network Procedures**

- 1110 Isolating Local Area Network Problems 11-2
- 1120 Local Area Network Diagnostic Tests 11-3
- 1130 Local Area Network Card Switch Setup 11-4

---

## 1110 Isolating Local Area Network Problems

This procedure uses SSP procedures (for example, PROBLEM) to diagnose local area network problems. Use this procedure to diagnose local area network problems when no SRCs are specified, or when the SRC does not isolate a specific FRU, or area of the local area network.

1. Run online problem determination.
  - a. Key in PROBLEM and press the Enter key.
  - b. Select the Local Area Network option.
  - c. Follow the prompts.

STATEST will allow concurrent testing of LAN. (For example: Exercise test on line 9 with line 10 enabled.)

2. Run STATEST.
  - a. Key in STATEST and press the Enter key.
  - b. Follow the prompts.

STATEST required field entries:

- a. Communication line numbers. (9 or 10)
- b. Number of test transmissions. (1 to 999)
- c. Number of seconds between transmissions. (0 to 20)

Press Enter.

- a. Select option 2. (Specify an SSP-ICF subsystem configuration to be tested.)

Press Enter.

- a. Subsystem configuration name. (This information must be obtained from the customer.)
- b. Library containing the configuration. (This information must be obtained from the customer.)

Press Enter.

- a. Select the location of the system to be tested.

Press Enter.

- a. Select option 5 to begin the test.

If test fails to run to completion, replace the FRUs indicated by the SRC.

## 1120 Local Area Network Diagnostic Tests

This procedure uses SSP procedures (for example, PROBLEM) to diagnose local area network problems. Diagnostic tests for the local area network will attempt to locate problems in internal and external local area network communications interfaces. There are three types of diagnostic tests for the local area network:

- Diagnostic tests during IPL
- Diagnostic tests during on-line problem determination
- Diagnostic tests during concurrent maintenance

### Diagnostic Tests During IPL

Diagnostic tests during IPL test the local area network adapter.

### Diagnostic Tests During On-line Problem Determination

Diagnostic tests during on-line problem determination test the local area network hardware.

### Diagnostic Tests During Concurrent Maintenance

Station test (STATEST) permits on-line testing between the system and the local area network.

1. Run STATEST.
  - a. Key in STATEST and press the Enter key.
  - b. Follow the prompts.

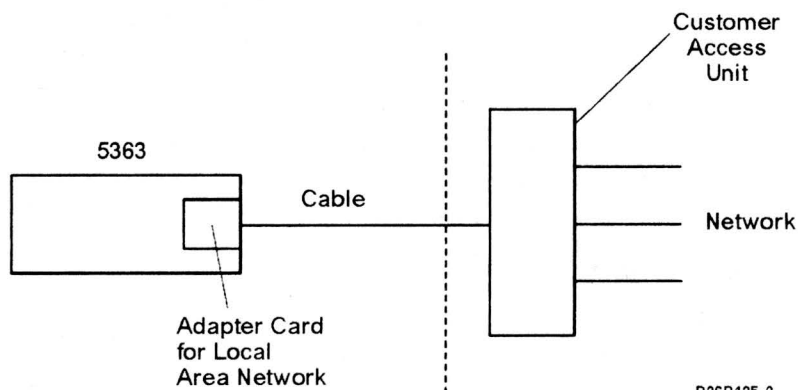

# 1130 Local Area Network Card Switch Setup

The system may have either or both of the following Local Area Network cards.

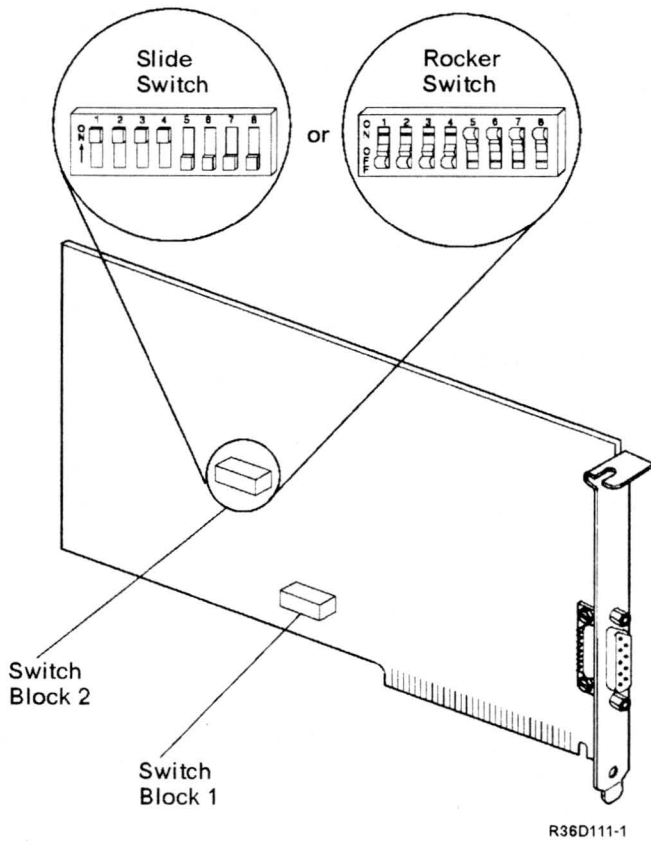

Switch Block 1 and Switch Block 2 on the first LAN card should be set as follows:

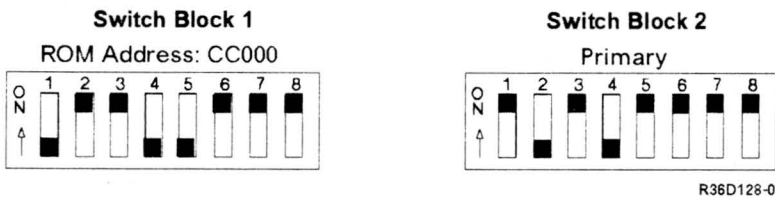

If you have *two* LAN cards in the same system unit, Switch Blocks 1 and 2 on the second LAN card should be set as follows:

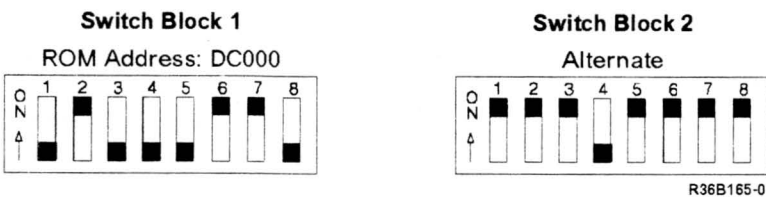

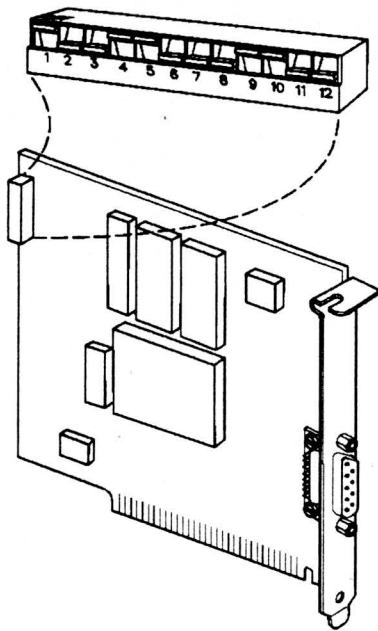

R36B168-0

The switch block on the first LAN card should be set as follows:

ROM Address: CC000

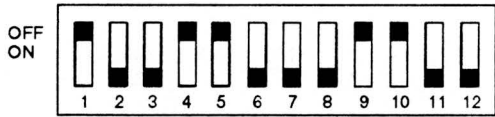

R36B169-0

If you have *two* LAN cards in the same system unit, the switch block on the second LAN card should be set as follows:

ROM Address: DC000

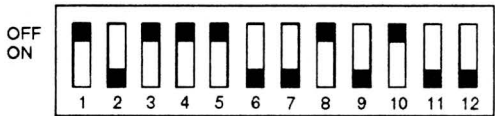

R36B170-0





# Appendix A. AC Safety Grounds

The figure below is an AC grounding diagram. All J-connectors on this page have green and yellow wires that are AC safety grounds. All AC safety ground wires must be installed correctly.

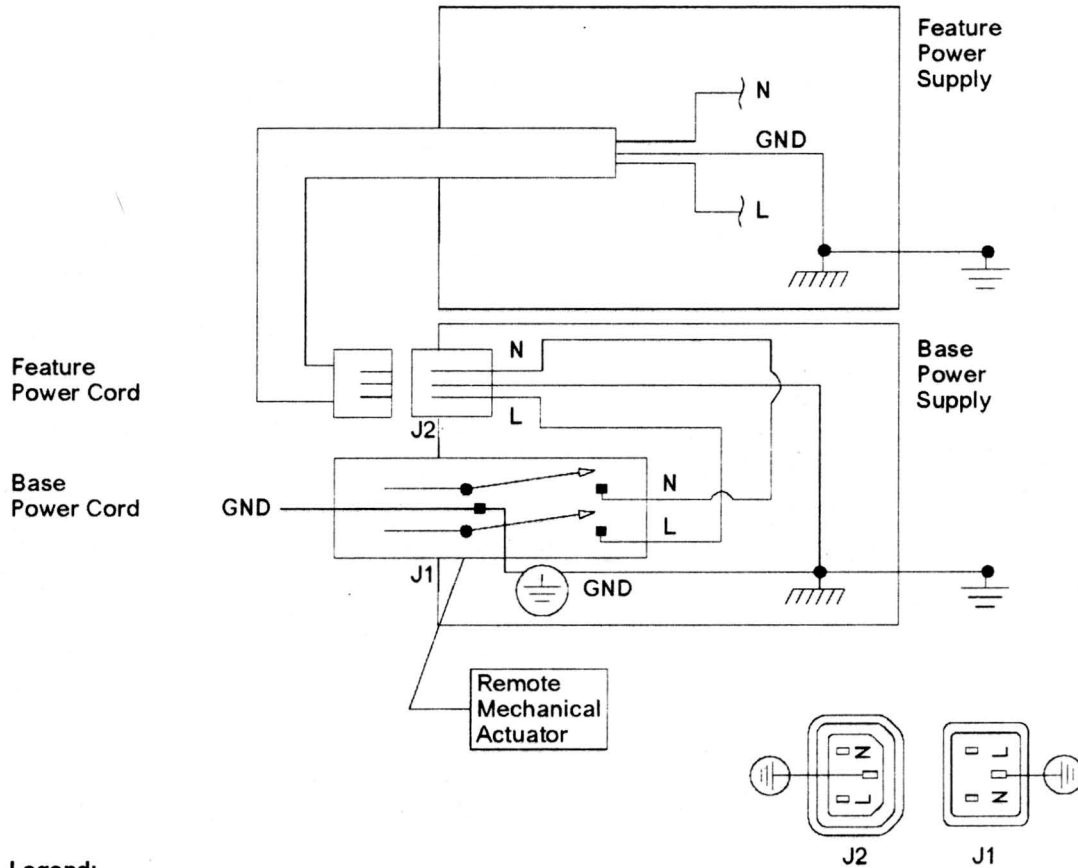
**AC Safety Grounds**



**Legend:**

-  Chassis Ground
-  Frame or System Ground

R36B134-5



---

## **Appendix B. Safety Inspection Guide**

---

### **Getting Ready**

Before performing the inspection procedures contained in this guide, ensure that present conditions are safe, the machine is powered off, and the power cord is disconnected.

### **Safety Conditions**

If present conditions are not safe, you must determine if the condition is serious. For example, the following conditions are not safe:

- Electrical: In the primary power area, a frame that is not grounded
- Mechanical: Missing covers
- Other: Leaking capacitors or a damaged CRT face

You must determine if the problem should be repaired before you can continue with this inspection.

### **Safety Education**

Before performing the inspection procedures contained in this guide, you must have completed the General Safety Training Course (latest level).

### **Chemicals**

Do not use solvents, cleaners, or other chemicals not approved by IBM.

### **Performing the Inspection**

The design and assembly of IBM machines includes safety items installed to protect operators and service representatives from injury. This inspection guide identifies areas of the machine that may not be safe. Use good judgment to identify other safety conditions not covered by this inspection guide.

---

## Power Cord

### Check Step

- Disconnect the power cord at the customer power outlet.
- Check the power cord for visible cracks, wear, or damage.
- Ensure that the power cord has the correct power plug. See the manual *Setting Up Your Computer* – 5363, SA21-9926, for the correct plug type.
- Check for 0.2 ohm or less of resistance between the power cord ground and the ground pin on the power plug (customer end).

---

## AC Safety Grounds

### Check Step

- Ensure that **all** of the AC safety ground screws shown in Appendix A are tight.
- Check the power area for loose or damaged cables.
- Check the inside of the system for foreign materials.

---

## Safety Labels

### Check Step

- Ensure that the system has all of the safety labels shown below. The label shown is on the base power supply. The same label appears on the feature power supply if one is present.

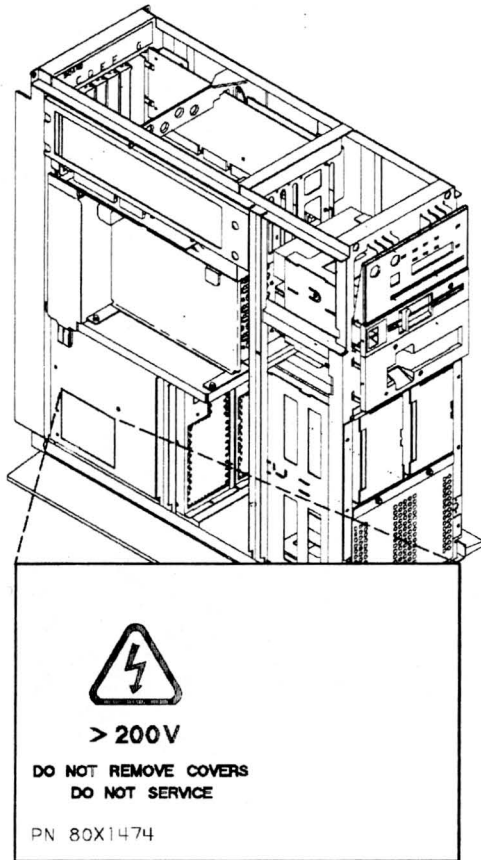

R36B136-2

---

## System Covers

### Check Step

- Disconnect the power cord from the customer power outlet.
- Ensure that the system covers are not loose or broken.
- Ensure that the covers have no sharp edges.
- Return the system to the customer and inform the local branch office that the safety inspection is complete.



---

## **Appendix C. Working with ESD-Sensitive Cards**

When handling or inserting ESD-sensitive cards, use the ESD (electrostatic discharge) handling kit, IBM part 6428316 or similar. Read the instructions located inside the top cover of the carrying case.



## Appendix D. Glossary

This glossary includes terms and definitions from the *IBM Vocabulary for Data Processing, Telecommunications, and Office Systems*, GC20-1699.

**A.** Ampere.

**ac.** Alternating current.

**ACR.** Abandon call and retry.

**alter.** To change something. Same as *modify*.

**ALTERCOM.** Alter communications (configuration procedure). See also *SETCOMM*.

**alternative cylinder.** A cylinder on a diskette that is used by the system when the selected cylinder cannot be used.

**alternative sector.** A sector on a disk that is used by the system when the selected sector cannot be used.

**APAR.** Authorized program analysis report.

**assistance.** Aid. See also *RETAIN*.

**Attn.** Attention (key).

**authorized program analysis report.** A request for correction of a problem caused by a defect in the present release of a program.

**auto.** Automatic.

**backup.** Pertaining to a system, device, or file that can be used in the event of a failure or loss of data. See *backup copy*, *backup diskette*, and *switched network backup (SNBU)*.

**backup copy.** A copy of a file or data set that is kept for reference in the event the original file or data set is destroyed. See also *backup diskette*.

**backup diskette.** A diskette that contains information that was copied from a diskette or from disk. The backup diskette is used in the event the original information is accidentally altered or destroyed. See also *backup copy*.

**batch.** A group of records or jobs put together for processing or transmission.

**binary synchronous communications.** A type of line control with a set of rules for transmitting data over a communications line connecting two devices that use a communications adapter.

**BSC.** Binary synchronous communications.

**BSCTEST.** BSC online test (procedure). See also *COMMTEST*, *SDLCTEST*, and *STATEST*.

**call.** (1) A service call. (2) To activate a program or procedure at its entry point. (3) In data communications, the action performed by the calling person or station, or the operations necessary in making a call, or the effective use made of a connection between two stations.

**call request.** To request a call. See also *call*.

**called station.** On a switched line, in data communications, the location to which a connection is made.

**calling station.** On a switched line, in data communications, the location making a connection.

**CCITT.** The International Telephone and Telegraph Consultative Committee.

**CE cylinder.** An area on disk that is used as a read/write area for diagnostic testing.

**CE track.** See *CE cylinder*.

**CEB.** Channel error byte.

**clocking.** In data communications, the use of clock pulses to control synchronization of data and control characters.

**Cmd.** Command (key).

**CNTLCOMM.** Control communications (procedure).

**COMCNFIG.** Communications configuration.

**COMM.** Communications.

**COMMTEST.** Communications concurrent diagnostic test (procedure). See also *BSCTEST*, *SDLCTEST*, and *STATEST*.

**completion code.** See *condition code*.

**condition code.** A code that shows the results of a processing operation.

**configure.** To make or describe a configuration.

**control panel.** A panel that contains keys, lights, and displays used by the operator (for normal operation) and by the service representative (for system maintenance).

**control storage directory.** An area on disk that contains the address of all programs in the control storage library.

**control storage library.** An area on disk that contains the diagnostic programs that are loaded to control storage.

**CRC.** Cyclic redundancy check (character).

**CRQ.** Call request.

**CSP.** Control storage processor.

**CSU.** Customer setup.

**CTS.** Clear to send.

**customize.** To update the unit definition table and system microcode on disk. See also *system customize utility*.

**cycle steal.** The process by which a device uses cycles of another machine or device. If, for example, the processing unit is performing an ALU operation when the disk needs service, the ALU operation is stopped while a byte of data is moved to or from the disk.

**cyclic redundancy check character.** A character code used for error sensing and correction.

**cylinder.** In disk and diskette storage devices, a cylinder contains all the data under all heads without moving the actuator or the head and carriage assembly.

**data set ready.** A communications signal that indicates that the modem is ready to transmit or receive data.

**data terminal equipment.** The processing unit that uses data communications lines.

**data terminal ready.** An EIA/CCITT interface line that signals the modem when the terminal is ready to transmit or receive data.

**dB.** Decibel.

**DBI.** Data bus in.

**dBm.** Decibel based on one milliwatt.

**DBO.** Data bus out.

**DCE.** Data communications equipment.

**DCP.** Diagnostic control program.

**DDSA.** Digital Data Service Adapter.

**DE.** Disk enclosure.

**decibel.** A unit of measure that is the ratio of two power or voltage levels.

**dedicated.** (1) Pertaining to one application or purpose. (2) A time during maintenance when no customer jobs are running.

**defect.** (1) A failure. (2) A bad area on a disk, diskette, or tape surface. (3) An error in a released program or program module.

**determination.** See *problem determination*.

**diagnostic control program.** The supervisor program that controls diagnostic programs.

**Digital Data Service Adapter.** In data communications, a device used in place of a modem when transmitting data over the AT&T Digital Data Service Network. (A DDSA can also be used for local connections.)

**directory.** See *control storage directory* and *diskette directory*.

**disk enclosure.** The sealed unit of the disk storage device that contains the disks, the spindle, and the actuator.

**diskette directory.** An area of a diskette that contains the addresses of all records on the diskette.

**DLO.** Data line occupied.

**DMR.** Data modem ready.

**DPR.** Digit present.

**DSA.** Data storage attachment/adapter.

**DSKTEST.** Diskette test (procedure).

**DSR.** Data set ready.

**DTE.** Data terminal equipment.

**DTR.** Data terminal ready.

**dump.** (1) To copy the contents of all or part of storage, usually from storage to an output device.  
(2) Data that has been dumped.

**duplex.** A data communications network that permits data communications in opposite directions at the same time. See also *half duplex*.

**EIA.** Electronic Industries Association.

**enclosure.** See *disk enclosure (DE)*.

**ERAP.** Error recording analysis procedure.

**fix.** See *MPTF* and *PTF*.

**free-lance.** To diagnose machine problems with minimum instructions.

**FRU.** Field-replaceable unit.

**full duplex.** Same as *duplex*.

**half duplex.** Permitting data communications in opposite directions, but not at the same time. See also *duplex*.

**Help.** (1) A key on work station keyboards. (2) A display that gives additional information about the task you are performing. (3) A system procedure that displays a sequence of menus associated with system tasks.

**hex.** Hexadecimal.

**I/O panel.** An area of a machine where I/O cables are connected to the system. This area is accessible to the customer.

**ICF.** Interactive communications feature.

**ID.** Identifier.

**identifier.** A label or name that identifies something.

**IL.** Interrupt level.

**ILBB.** Interrupt level backup byte.

**IM.** Integrated modem.

**initial program load.** A sequence of events that loads the system programs and prepares the system to run jobs.

**IPL.** Initial program load.

**K.** 1024, when making reference to a quantity of data or data storage.

**Kb.** 1024 bytes. (Kb may also be displayed as KB.)

**LAN.** Local area network.

**line filter.** A device used to prevent ripple or electrical noise on the AC power source from reaching machine power supplies and to prevent ripple or electrical noise generated by a machine from reaching the AC power source.

**local storage register.** A register used for general-purpose storage.

**log.** (1) A document containing written entries. (2) A system record containing recorded entries. (3) To write or record an entry in a log.

**logged.** Having written or recorded an entry in a log.

**loopback test.** A test in which signals are looped from a test unit, through a data set or loopback switch, and back to the test unit for measurement.

**LPDA.** Link Problem Determination Aid.

**LSR.** Local storage register.

**M.** 1 048 576, when making reference to a quantity of data or data storage. See also *megabyte*.

**MAP.** Maintenance analysis procedure.

**Mb.** 1 048 576 bytes. (Mb may also be displayed as MB.) See also *megabyte*.

**megabyte.** 1 000 000 bytes, when making reference specifically to the storage size of a disk storage device. See also *M* and *Mb*.

**MIM.** Maintenance information manual.

**MLCA.** Multiline communications attachment/adapter.

**modifier.** Something that modifies or changes.

**modify.** To change something. Same as *alter*.

**MPTF.** Microprogram temporary fix.

**MS.** Main storage.

**MSP.** Main storage processor.

**multidevice.** More than one device.

**multiline.** More than one communications line.

**multinational.** More than one country.

**multiple.** More than one.

**multipoint.** In data communications, a network that has more than one station.

**OC.** Overcurrent.

**occupied.** Busy. See also *DLO*.

**OV.** Overvoltage.

**overcurrent.** A condition that occurs when power supply current is too high.

**overview.** A summary.

**overvoltage.** A condition that occurs when power supply voltage is too high.

**panel.** See *I/O panel* and *control panel*.

**PEB.** Processor error byte.

**PND.** Present next digit.

**POR.** Power-on reset.

**problem determination.** The process of identifying why the system is not working. Often this process identifies programs, hardware, data communications equipment, or user errors as the source of the problem.

**program temporary fix.** A temporary solution or bypass of a problem diagnosed by IBM service representatives as a result of a defect in an existing program. See also *authorized program analysis report (APAR)*.

**protocol.** In SNA, the rules for transmitting and receiving data.

**PTF.** Program temporary fix.

**PUMP.** Pack utility maintenance program.

**R/W.** Read/write.

**RDS.** Receive data space.

**reflection.** Part of a signal that returns to its source because of a change in the impedance of the cable in which the signal travels.

**reload.** To load programs again (as from diskettes).

**RETAIN.** Remote technical assistance information network.

**retainer.** a device used to prevent logic cards and cables from becoming loose.

**retry.** An attempt to perform an operation a specified number of times, or until the operation is completed. See also *ACR*.

**RFI.** Radio frequency interference.

**RNR.** Receive not ready.

**ROS.** Read-only storage.

**RPQ.** Request for price quotation.

**RS-232-C.** An EIA interface specification.

**RTR.** Ready to receive.

**RTS.** Request to send.

**RWS.** Remote work station.

**SA.** Service aid.

**SDLC.** Synchronous data link control.

**SDLCTEST.** SDLC online test (procedure). See also *BSCTEST*, *COMMTEST*, and *STATEST*.

**SETCOMM.** Set communications (configuration procedure). See also *ALTERCOM*.

**SLCA.** Single-line communications adapter.

**SNA.** Systems network architecture.

**SNA profile.** A description of the characteristics of a systems network architecture protocol.

**SNBU.** Switched network backup.

**spindle.** The shaft that turns the disk.

**SRC.** System reference code.

**SSA.** Sequential sector address.

**SSP.** System support program product.

**STATEST.** Station test (procedure). See also *BSCTEST*, *COMMTEST*, and *SDLCTEST*.

**supervisor call.** An instruction that causes control to be passed to the control storage processor.

**SVC.** Supervisor call.

**switched network backup.** In data communications, an alternative method of connecting two systems over telephone lines when the primary method of connection is by leased lines.

**synchronous data link control.** Rules that control data movement over a communications line connecting two devices that use a communications adapter.

**Sys Req.** System Request (key).

**system customize utility.** A utility under dedicated DCP that lets you update the system microcode on disk, using the diagnostic diskettes.

**system reference code.** A 4-character code displayed as part of a system message, as part of a diagnostic message, or displayed in the control panel display.

**systems network architecture.** An IBM communications protocol for controlling information transfer in a data communications network.

**SYSTEST.** System test.

**task.** A unit of work.

**TB.** Terminal block.

**TCC.** Top card connector.

**TDS.** Transmit data space.

**Tektronix.** Trademark of Tektronix, Inc.

**template.** An overlay panel used as a mask to interpret the communications line status or autocal status displayed in the 4-character display on the control panel.

**TESTREQ.** Test request (procedure).

**TI.** Test indicate.

**TP.** Test point.

**trade.** See *World Trade*.

**TU.** Test unit.

**twinaxial cable.** A twisted-pair shielded cable that connects a keyboard/display or work station printer to the system.

**UDT.** Unit definition table.

**undervoltage.** A condition that occurs when power supply voltage is too low.

**unit definition table.** An area on disk or in storage that contains entries that describe the devices that run under control of the SSP.

**UV.** Undervoltage.

**V.** Volt.

**Vac.** Volts, alternating current.

**Vdc.** Volts, direct current.

**World Trade.** Pertaining to all countries except the U.S. and Canada.

**wrap tests.** I/O device diagnostic tests that run when the Load key is pressed.

---

## Appendix E. Parts Catalog

Cable List	E-17
Covers and Bezels	E-4
Disk Drive-Logic Card Asm	E-14
Disk Drives, Power, Fan, and Frame	E-8
Logic Asm, Diskette, and Tape Drives	E-6
Logic Unit Assembly	E-12
Main Cover Assembly	E-10
Power Cord Chart	E-16
Tape Unit-Bracket Asm, 120 Mb	E-15
<b>Part Number Index</b>	<b>E-19</b>

## How To Use This Parts Catalog

• **SIMILAR ASSEMBLIES:** If two assemblies contain a majority of identical parts, they are broken down on the same list. Common parts are shown by one index number. Parts peculiar to one or the other of the assemblies are listed separately and identified by description.

• **AR:** (As Required) in the Units column indicates that the quantity is not the same for all machines.

• **NP:** (Non-Procurable) in the Units column indicates that the part is non-procurable and that the individual parts or the next higher assembly should be ordered.

• **NR:** (Not Recommended) in the Units column indicates that the part is procurable but not recommended for field replacement, and that the next higher assembly should be ordered.

• **R:** (Restricted) in the Units column indicates that the part has a restricted availability.

• **INDENTURE:** The indenture is marked by a series of dots located before the parts description. The indenture indicates the relationship of a part to the next higher assembly. For example:

### Indenture Relationship of Parts

(No dot) MAIN ASSEMBLY

(One dot) • Detail parts of a main assembly

(One dot) • Sub assembly of the main assembly

(Two dot) • • Detail part of a one-dot sub assembly

(Two dot) • • Sub assembly of a one-dot sub assembly

(Three dot) • • • Detail part of a two-dot sub assembly

Asm-Index	Part Number	Units	Description
3-	2512667	1	Cover Asm, Rear, Red
	2513714	1	Cover Asm, Rear, White
			For Next Higher Asm, See Assembly 1-2
-1	5373637	1	•Seal, Top
-2	5356429	2	•Clip, Retaining
-3	1847630	1	•Finger Stock Asm
-4	1847602	NR	••Channel, Finger Stock
-5	5373639	AR	•Seal, Bottom
-6	5356429	2	•Clip, Retaining
-7		NP	•Cover, Rear, Without Paint
-5	0416629	R	•Screw, Panel



# Assembly 1: Covers and Bezels

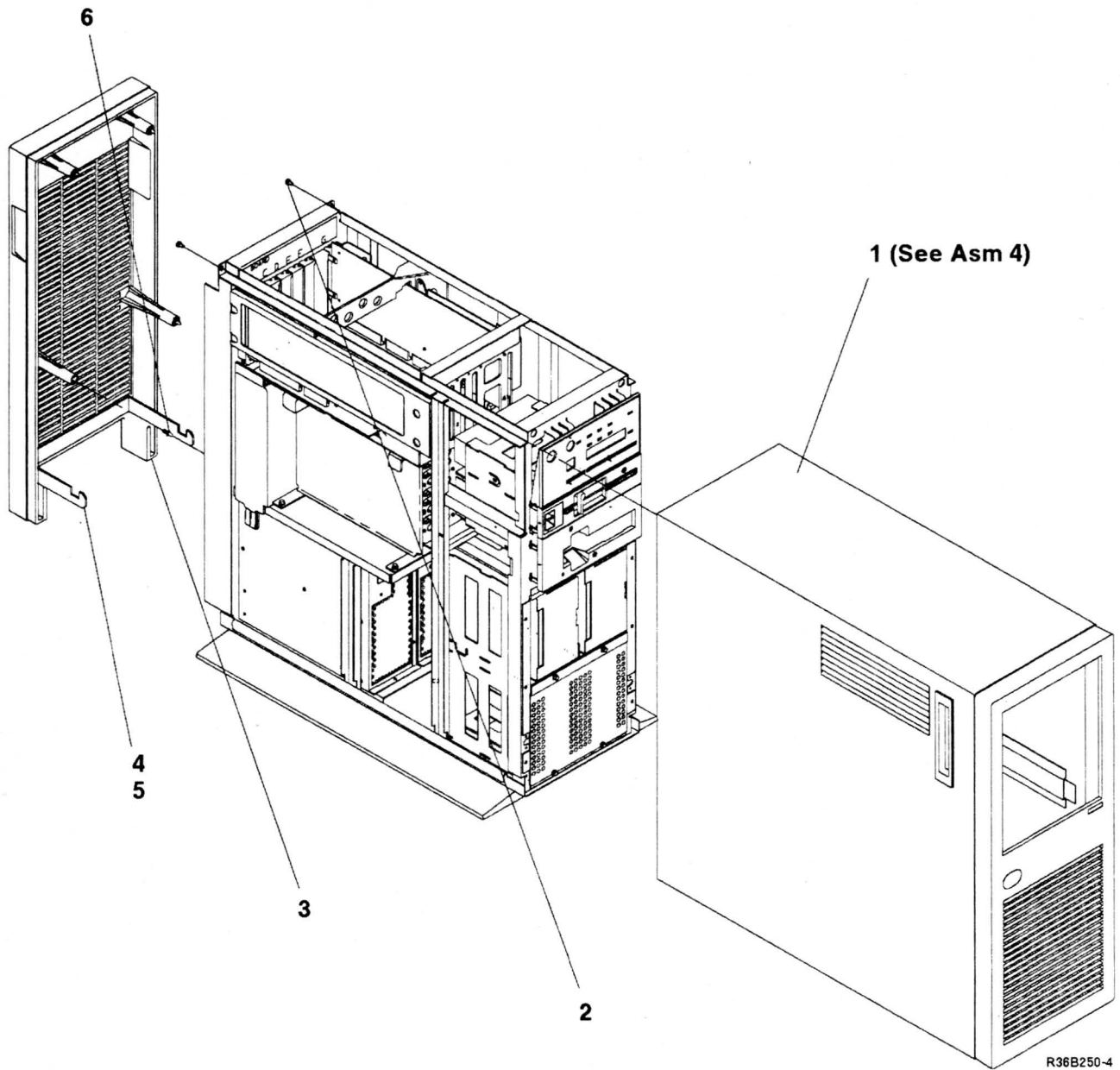

Asm - Index	Part Number	Units	Description
1-1	None	1	• Cover Asm, (See Asm 4)
-2	1621812	2	• Screw,
-3	92X3307	1	• Cover Asm - Rear
-4	92X3249	1	• Safety Latch
-5	2549531	3	• Screw,
-6	8232317	4	• Ball Stud

## Assembly 2: Logic Asm, Diskette, and Tape Drives

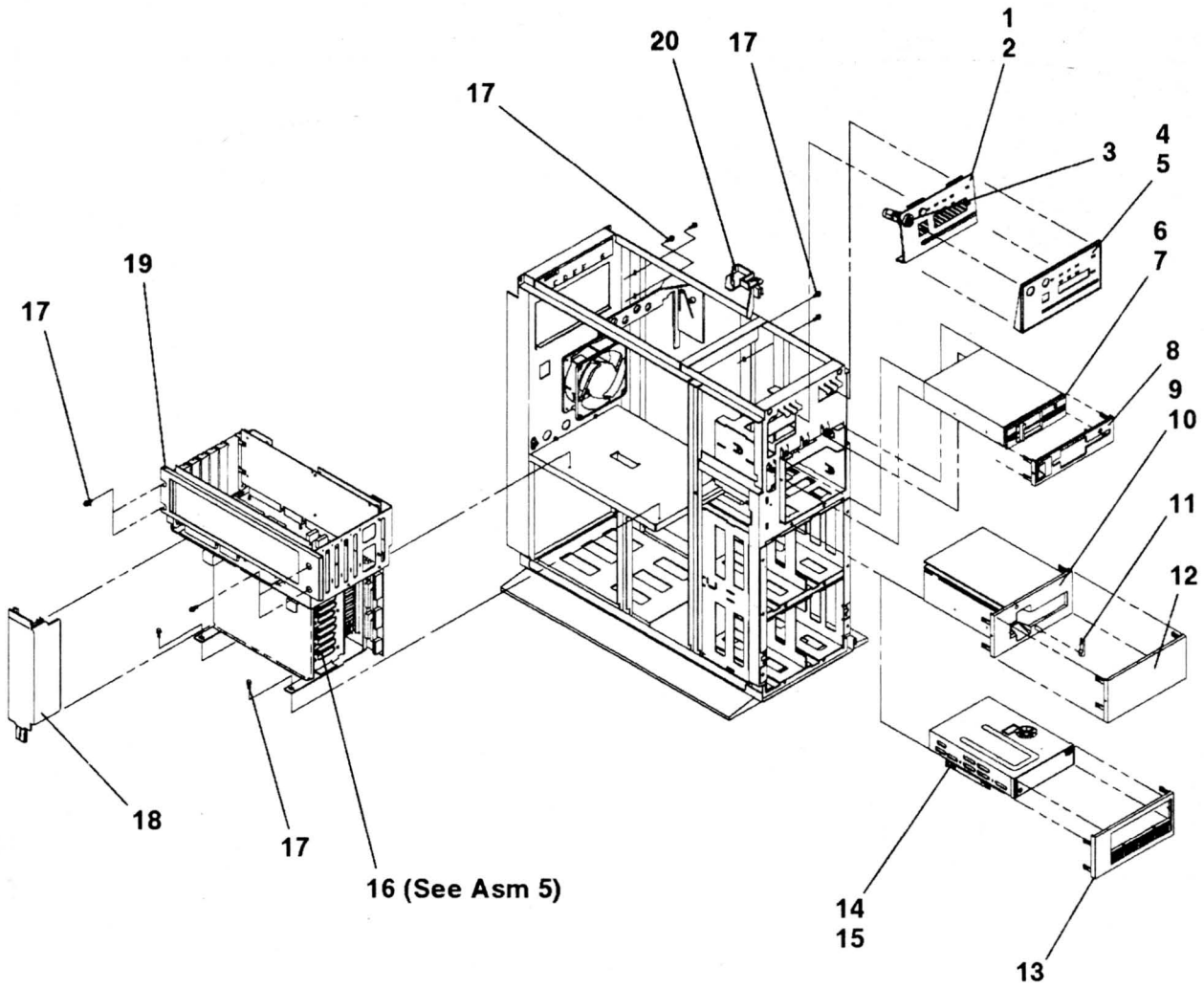

R36B251-7

Asm - Index	Part Number	Units	Description
2-1	92X3214	1	• Operator Panel
-2	1622676	2	• Screw,
-3	2595136	1	• • Keylock,
-4	92X3335	1	• Bezel, Operator Panel
-5	92X3344	1	• Label, OP Panel-English
-5	92X7202	1	• Label, OP Panel-French
-5	92X7205	1	• Label, OP Panel-German
-5	92X7208	1	• Label, OP Panel-Italian
-5	92X7211	1	• Label, OP Panel-Kanji
-5	92X7217	1	• Label, OP Panel-Spanish
-5	92X7220	1	• Label, OP Panel-French/Canadian
-5	92X7244	1	• Label, OP Panel-Hangeul
-5	92X7247	1	• Label, OP Panel-Chinese
-5	92X7250	1	• Label, OP Panel-Hanzi
-6	6369881	1	• Diskette Drive (5.25)
-7	1624743	3	• Screw,
-8	92X3336	1	• Bezel-On/Off, Diskette
-9	92X3382	1	• Tape Drive Asm, 53 Mb
-10	740501	4	• Screw,
-11	6453929	1	• Tape Lever Kit
-12	92X3309	1	• Bezel-Blank
-13	92X7499	1	• Bezel-Tape, 120 Mb
-14	92X4180	1	• Tape Drive Unit, 120 Mb
-14	21F4126	1	• Tape Drive-Bracket Asm, 120 Mb (Field Upgrade Only, See Assembly 7 for Parts Breakdown)
-15	1624743	4	• Screw,
-16	92X3402	NP	• Logic Unit Asm (See Assembly 5)
-17	1621812	10	• Screw,
-18	92X3361	1	• Cover, Fan-Air Flow
-19	92X3259	1	• Bracket, Support (Logic Frame)
-20	92X6456	1	• Retainer - 2 Mb

# Assembly 3: Disk Drives, Power, Fan, and Frame

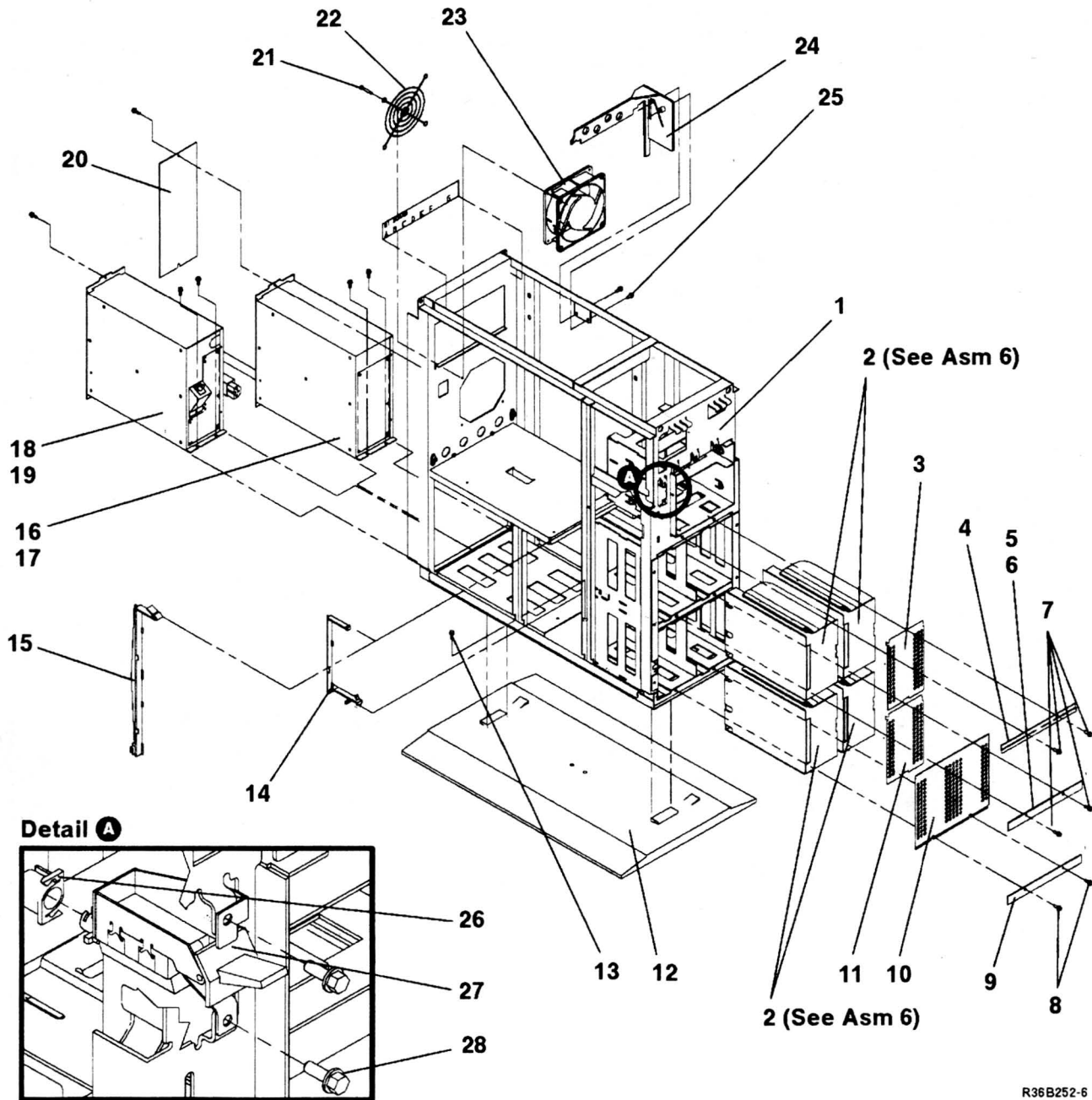

R36B252-6

Asm - Index	Part Number	Units	Description
3-1	92X3334	NP	• Main Frame Asm
-2	69X6909	1	• Disk Drive (65MB)
-2	92X7320	1	• Disk Drive (105MB)
-2	21F4250	1	• Disk Drive (314MB)
-3	92X3381	1	• Plate, Blank (DASD 2 & 4)
-4	92X3346	1	• Retainer Plate (Top)
-5	92X3345	1	• Retainer Plate (Center, DASD 1 & 2)
-6	92X6461	1	• Retainer Plate (Center, DASD 3 & 4)
-7	1624746	6	• Screw,
-8	1624746	2	• Screw,
-9	92X6462	1	• Retainer Plate (Bottom, DASD 3 & 4)
-10	92X3347	1	• Retainer Plate (Bottom, DASD 1 & 2)
-11	92X3381	1	• Plate, Blank (DASD 2 & 4)
-12	92X3337	1	• Pedestal
-13	1622695	1	• Screw,
-14	92X7346	2	• Cable Retainer (DASD 1 & 2)
-15	92X6460	2	• Cable Retainer (DASD 3 & 4)
-16	1035808	1	• Power Supply, (Feature) (All countries except - Europe, Middle East, and Africa)
-16	1035809	1	• Power Supply, (Feature) (Europe, Middle East, and Africa)
-17	1621812	4	• Screw,
-18	1035807	1	• Power Supply, (Base)
-19	1621812	4	• Screw,
-20	92X3343	1	• Cover, Blank-Power Supply
-21	2181002	2	• Screw, Fan Guard Mounting
-22	6195581	1	• Guard - Fan
-23	4236949	1	• Fan
-24	92X7312	1	• Card Retainer
-25	1622676	1	• Screw,
-26	92X3314	1	• Cable Asm, On/Off
-27	92X3310	1	• Acuator, On/Off (White Handle)
-28	1624743	2	• Screw,

**Assembly 4: Main Cover Assembly**

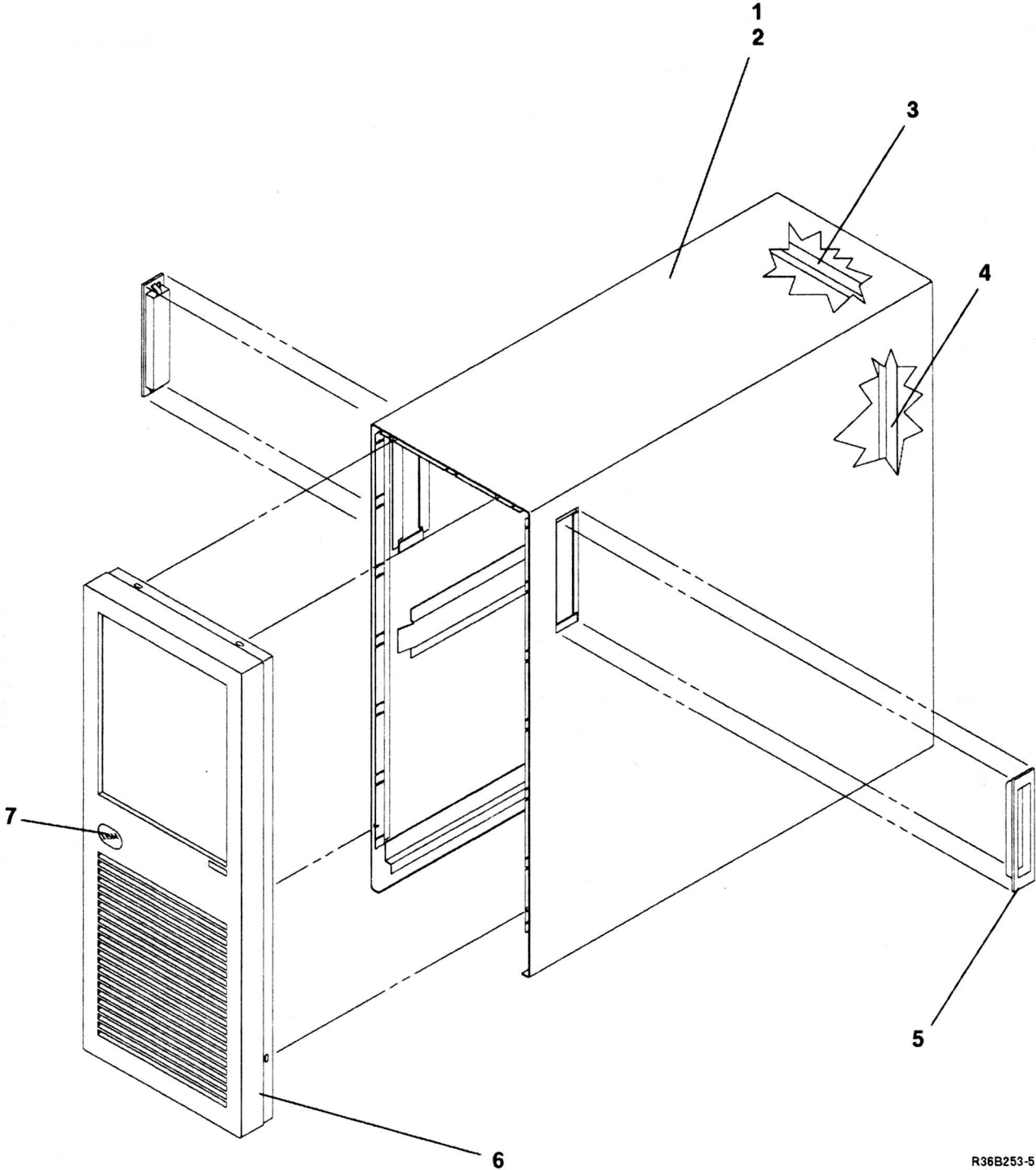

R36B253-5

Asm— Index	Part Number	Units	Description
4—	None		COVER ASSEMBLY
-1	92X3308	1	• Main Cover Assembly
-2	92X3319	1	• • Main Cover
-3	92X7318	1	• • Seal, Top
-4	92X7319	1	• • Seal, Bottom
-5	92X3318	2	• • Hand Hole Asm
-6	92X3306	1	• Front Cover
-7	92X3348	R	• Logo Plate, Level 0
-7	92X6500	R	• Logo Plate, Level I
-7	92X7235	R	• Logo Plate, Level II
-7	92X3290	R	• Logo Plate, Level III (5363 III)
-7	92X3297	R	• Logo Plate, Level IV (5363 IV)
-7	21F4196	R	• Logo Plate, Level III (Application System/Entry 5363 III)
-7	21F4197	R	• Logo Plate, Level IV (Application System/Entry 5363 IV)

## Assembly 5: Logic Unit Assembly

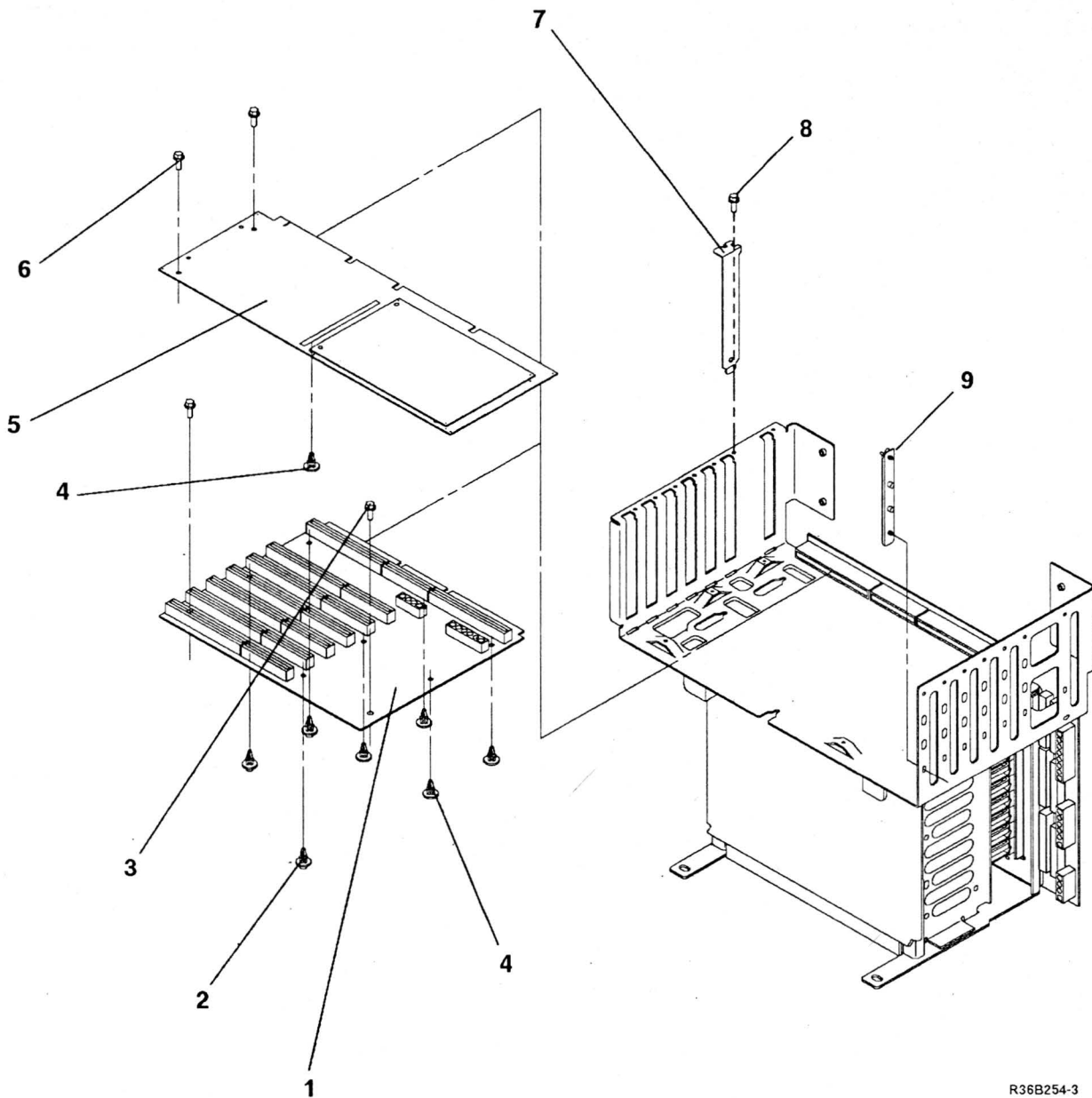

R36B254-3

Asm - Index	Part Number	Units	Description
5-	92X3402	NP	LOGIC UNIT ASSEMBLY
-1	92X7296	1	• B1 Board-Feature (Model 10,20)
-2	92X3324	3	• Standoff
-3	61X8794	2	• Screw,
-4	92X3326	5	• Standoff
-5	92X3222	1	• Main Storage Card Asm
-6	5700484	2	• Screw,
-7	1501437	AR	• Blank,
-8	61X8794	AR	• Screw,
-9	92X3367	AR	• Card Guide

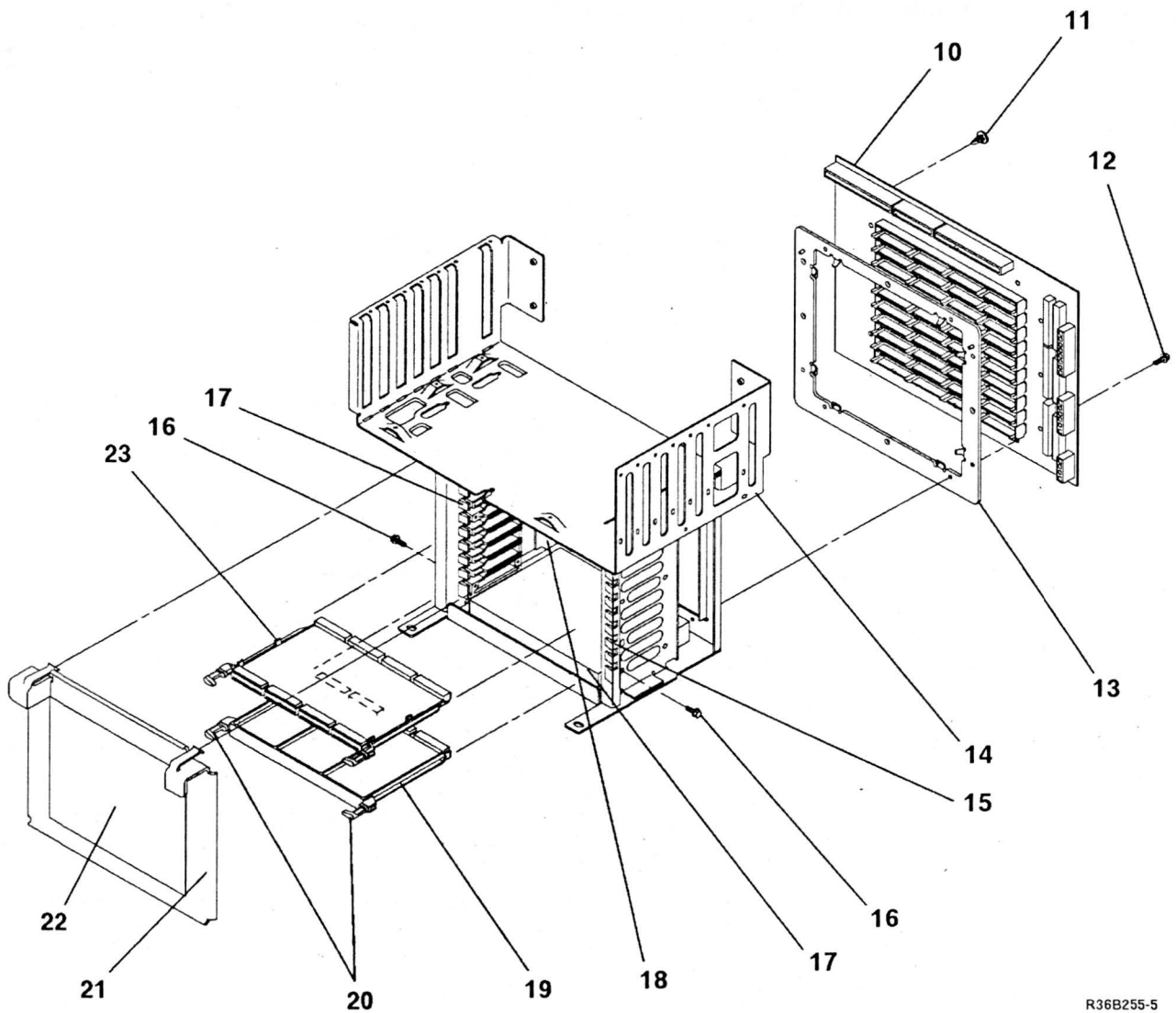

R36B255-5

Asm- Index	Part Number	Units	Description
5-10	92X7243	1	• A1 Board
-11	92X3326	7	• Standoff,
-12	1621811	12	• Screw,
-13	92X3329	1	• Spacer,
-14	92X3322	1	• Logic Support Frame
-15	92X3323	2	• Card Guide
-16	2549526	12	• Screw,
-17	92X3328	1	• Foam, Lower
-18	92X3327	1	• Foam, Upper
-19	92X3330	3	• Filler Card
-20	2453240	20	• Retainer (Black)
-21	92X3325	1	• Logic Cover
-22	92X7281	1	• A1 Board Label, Level 0, II, and IV
-22	92X7471	1	• A1 Board Label, Level I and III
-23	92X3331	7	• Card Holders

## Assembly 6: Disk Drive-Logic Card Asm

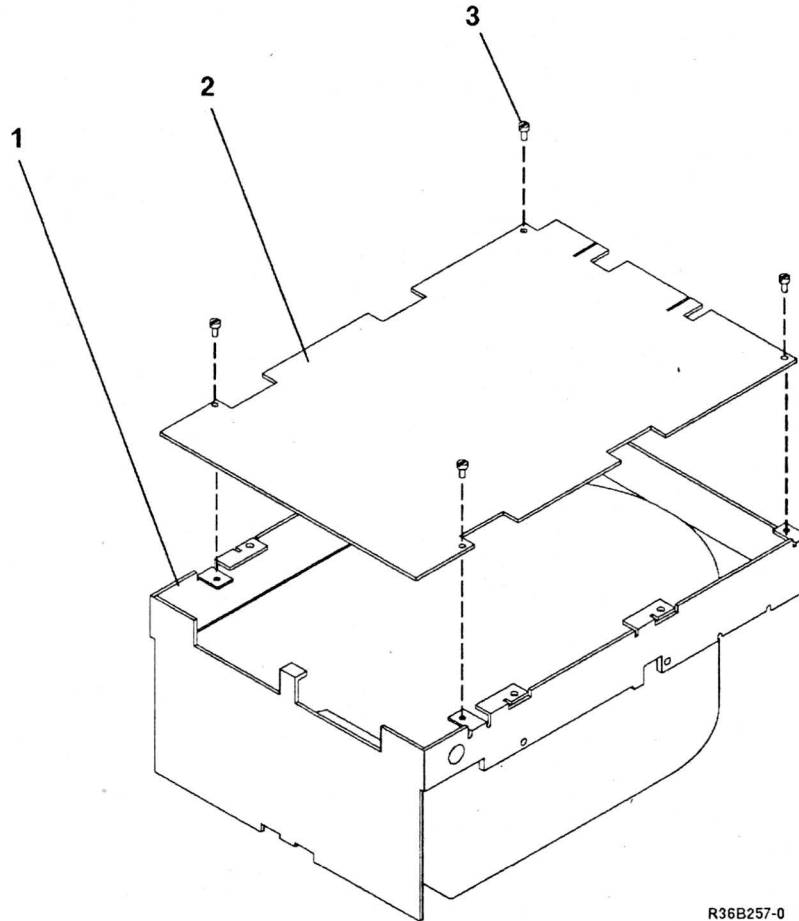

R36B257-0

Asm- Index	Part Number	Units	Description
6-	69X6909	AR	DISK DRIVE ASSEMBLY (65 Mb)
-	92X7320	AR	DISK DRIVE ASSEMBLY (105 Mb)
-	21F4250	AR	DISK DRIVE ASSEMBLY (314 Mb)
-1	69X6909	AR	• Disk Drive Assembly (65 Mb)
-2	6370793	1	• • Disk Drive Logic Card (65 Mb)
-3	xxxxxxx	4	• • Screw,
-1	92X7320	AR	• Disk Drive Assembly (105 Mb)
-2	6370951	1	• • Disk Drive Logic Card (105 Mb)
-3	xxxxxxx	4	• • Screw,
-1	21F4250	AR	• Disk Drive Assembly (314 Mb)
-2	21F4580	1	• • Disk Drive Logic Card (314 Mb)
-3	xxxxxxx	5	• • Screw,



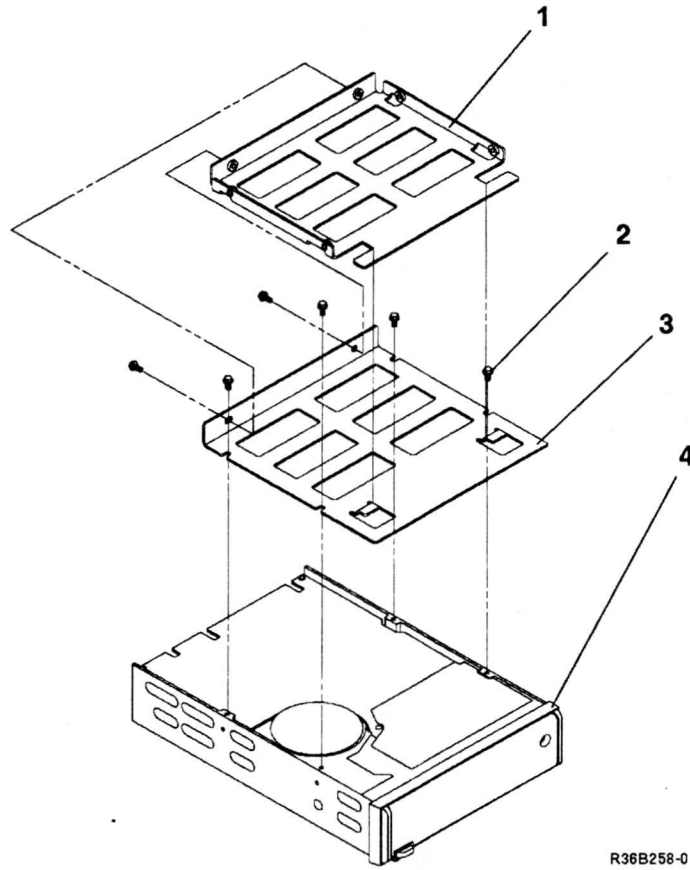







## Assembly 7: Tape Unit-Bracket Asm, 120 Mb



R36B258-0

Asm - Index	Part Number	Units	Description
7-	21F4126		TAPE UNIT-BRACKET ASSEMBLY, 120 Mb
-1	21F4125	1	• Bracket Adapter
-2	1624743	6	• Screw,
-3	21F4124	1	• Bracket Adapter
-4	92X4180	1	• Tape Drive Unit, 120 Mb

## Assembly 8: Power Cord Chart

Plug	Power Cord P/N	Country
	2453011	6 Ft. Lg. U.S. (Chicago)
	2453010	10 Ft. Lg. Bahamas, Bermuda, U.S./Canada, Cayman Islands, Colombia, Costa Rica, Dominican Republic, Ecuador, Guatemala, Honduras, Japan, Korea (South), Panama, Philippines, Surinam, Taiwan, Trinidad, Venezuela
	4437612	50Hz Barbados, Bolivia, Guyana, Jamaica, Netherland Antilles, Thailand
	4437611	60Hz Peru
No Plug	4437621	60Hz Bermuda, Colombia, Nicaragua
No Plug	4437620	50Hz Argentina, Paraguay, Uruguay
	4437604	Italy, Chile
	2453003	Liechtenstein, Switzerland
	4437602	Denmark
	4437605	Israel
	4437606	Bangladesh, Burma, Pakistan, South Africa, Sri Lanka
	4437601	Bahrain, Channel Islands, Cyprus, Hong Kong, India, Ireland, Kenya, Kuwait, Malaysia, Oman, Qatar, Saudi Arabia, Sierra Leone, Singapore, United Kingdom, United Arab Emirates
	4437600	Austria, Belgium, Bulgaria, Egypt, Finland, France, Germany, Iceland, Lebanon, Luxembourg, Morocco, Netherlands, Norway, Portugal, Spain, Sweden, Turkey, Uruguay, Yugoslavia
	2453001	Australia, New Zealand

R36B256-1

## Assembly 9: Cable List

Asm - Index	Part Number	Units	Description
9 -	92X3300		Disk Drive A/B Cable
-	92X3312		Disk Drive C/D Cable
-	92X3301		Diskette Cable
-	92X3302		Operator Panel Cable
-	92X3303		Twinax Cable
-	92X3304		Mfg. Int. Cable
-	92X3313		Tape Cable, 53 Mb
-	21F4128		Tape Cable, 120 Mb
-	92X3310		Power Cable - Actuator
-	92X3314		Power Cable - Mechanical
-	92X7325		SDLC Comm Cable/W Wrap
-	92X7325		BSC Comm Cable/W Wrap
-	92X7323		ASYNC Comm Cable/W Wrap
-	92X7324		A Real Time Co-Processor Cable/W Wrap
-	92X7216		V.35 Comm Cable/W Wrap
-	6339098		LAN Comm Cable



# Part Number Index

Part Number	Asm- Index	Page	Part Number	Asm- Index	Page	Part Number	Asm- Index	Page
None	1-1	E-5	6453929	2-11	E-7	92X3361	2-18	E-7
	4-	E-11	69X6909	3-2	E-9	92X3367	5-9	E-12
740501	2-10	E-7		6-	E-14	92X3381	3-3	E-9
xxxxxxx	6-3	E-14		6-1	E-14		3-11	E-9
	6-3	E-14	8232317	1-6	E-5	92X3382	2-9	E-7
	6-3	E-14	92X3214	2-1	E-7	92X3402	2-16	E-7
1035807	3-18	E-9	92X3222	5-5	E-12		5-	E-12
1035808	3-16	E-9	92X3249	1-4	E-5	92X4180	2-14	E-7
1035809	3-16	E-9	92X3259	2-19	E-7		7-4	E-15
1501437	5-7	E-12	92X3290	4-7	E-11	92X6456	2-20	E-7
1621811	5-12	E-13	92X3297	4-7	E-11	92X6460	3-15	E-9
1621812	1-2	E-5	92X3300	9-	E-17	92X6461	3-6	E-9
	2-17	E-7	92X3301	9-	E-17	92X6462	3-9	E-9
	3-17	E-9	92X3302	9-	E-17	92X6500	4-7	E-11
	3-19	E-9	92X3303	9-	E-17	92X7202	2-5	E-7
1622676	2-2	E-7	92X3304	9-	E-17	92X7205	2-5	E-7
	3-25	E-9	92X3306	4-6	E-11	92X7208	2-5	E-7
1622695	3-13	E-9	92X3307	1-3	E-5	92X7211	2-5	E-7
1624743	2-7	E-7	92X3308	4-1	E-11	92X7216	9-	E-17
	2-15	E-7	92X3309	2-12	E-7	92X7217	2-5	E-7
	3-28	E-9	92X3310	3-27	E-9	92X7220	2-5	E-7
	7-2	E-15		9-	E-17	92X7235	4-7	E-11
1624746	3-7	E-9	92X3312	9-	E-17	92X7243	5-10	E-13
	3-8	E-9	92X3313	9-	E-17	92X7244	2-5	E-7
21F4124	7-3	E-15	92X3314	3-26	E-9	92X7247	2-5	E-7
21F4125	7-1	E-15		9-	E-17	92X7250	2-5	E-7
21F4126	2-14	E-7	92X3318	4-5	E-11	92X7281	5-22	E-13
	7-	E-15	92X3319	4-2	E-11	92X7296	5-1	E-12
21F4128	9-	E-17	92X3322	5-14	E-13	92X7312	3-24	E-9
21F4196	4-7	E-11	92X3323	5-15	E-13	92X7318	4-3	E-11
21F4197	4-7	E-11	92X3324	5-2	E-12	92X7319	4-4	E-11
21F4250	3-2	E-9	92X3325	5-21	E-13	92X7320	3-2	E-9
	6-	E-14	92X3326	5-4	E-12		6-	E-14
	6-1	E-14		5-11	E-13		6-1	E-14
21F4580	6-2	E-14	92X3327	5-18	E-13	92X7323	9-	E-17
2181002	3-21	E-9	92X3328	5-17	E-13	92X7324	9-	E-17
2453240	5-20	E-13	92X3329	5-13	E-13	92X7325	9-	E-17
2549526	5-16	E-13	92X3330	5-19	E-13		9-	E-17
2549531	1-5	E-5	92X3331	5-23	E-13	92X7346	3-14	E-9
2595136	2-3	E-7	92X3334	3-1	E-9	92X7471	5-22	E-13
4236949	3-23	E-9	92X3335	2-4	E-7	92X7499	2-13	E-7
5700484	5-6	E-12	92X3336	2-8	E-7			
61X8794	5-3	E-12	92X3337	3-12	E-9			
	5-8	E-12	92X3343	3-20	E-9			
6195581	3-22	E-9	92X3344	2-5	E-7			
6339098	9-	E-17	92X3345	3-5	E-9			
6369881	2-6	E-7	92X3346	3-4	E-9			
6370793	6-2	E-14	92X3347	3-10	E-9			
6370951	6-2	E-14	92X3348	4-7	E-11			







# Index

## A

- About This Manual iii
- AC point-to-point 4-10
- AC safety grounds A-1, B-2
- AC safety grounds 4-10
- actuator power on/off switch 4-4
- additional communications tests 9-4
- airflow fan cover 3-5
- alter storage function 3-23
- alter/display
  - control storage 3-23
  - disk storage 3-23
  - main storage 3-23
  - MSP registers 3-23
- alter/display function 3-23
- ALTERCOM 3-12, 9-5, 9-9
- altering storage 3-23
- analysis network procedure 7-2
- APAR 3-12
- ASYNCR communications 9-3
- asynchronous communication 9-11
- AUTO CONFIG 3-10
- auto configuring 3-8
- A1 board locations 2-9
- A1 board maximum ripple voltage table 4-13
- A1 board removal
  - removal A1 board 3-19
- A1 board switch settings
  - switch settings A1 board 3-22

## B

- base DC voltage distribution 4-11
- base DC voltage tolerances 4-13
- basic communications test 9-2, 9-4
- basic tests (COMMTEST) 3-11
- board locations 2-10
- BSC on line test 9-8
- BSCTEST 9-2
- BSCTEST (BSC on line test) 9-4, 9-8
- BSCTEST (BSC online test) 3-11, 3-12
- BUILD 3-12
- B1 board connectors 2-13
- B1 board maximum ripple voltage table 4-14
- B1 board reinstall 3-17
- B1 board removal 3-17

## C

- cable check (twinax) 7-15
- cable ohmmeter test 7-15
- cable problems, communications 9-3
- cabling system
  - sample oscilloscope signals 7-10
  - test 7-3
- card local area network (LAN) 11-4
- card location table 2-14
- cards, ESD-sensitive C-1
- caution notices vii
- channel overview 2-3
- check, removal, replace, power on/off actuator switch 4-4
- chemicals, use of B-1
- cleaners, use of B-1
- COMCNFIG STATUS 9-5
- COMM STATUS 9-5
- COMMTEST 3-11, 3-12, 9-2
  - additional communications tests 9-4
    - diagnostic 9-4
  - basic communications test 9-4
  - basic tests 3-11
  - IBM LPDA modem tests 3-11
  - print data traces 3-11
  - remote loopback tests 3-11
  - static driver off test 3-11
  - static driver on test 3-11
- communications
  - configuration 9-2
  - configuration status 9-5
  - exerciser 3-11
  - line status 9-6, 9-7
  - status 9-2
  - template 9-7
  - tests 9-4
- communications cable problems 9-3
- communications tests
  - basic test 9-2
  - concurrent 9-4
  - CSU 9-4
  - during IPL 9-4
  - during on line problem determination 9-4
- concurrent tests, communications 9-4
- configuration status, communications 9-2
- configuration, automatic 3-8
- connector (location) 4-11, 4-12
- control panel
  - removal 5-9
  - service check 5-4
  - symptom table 5-2
- control storage
  - alter/display 3-23

control storage directory, list 3-16  
COPY11 3-12  
cover removal 3-2  
covers, system/safety B-3  
CSU, communications 9-4  
customer IPL 3-8  
customer setup, communications 9-4  
customize load options 3-10  
customize, system 3-9

## D

D C 3-12  
D H 3-12  
danger notices vii  
DC base and feature voltage tolerances 4-13  
DC base voltage distribution 4-11  
DC feature voltage distribution 4-12  
DCP 3-10  
    See also utilities  
DCP load options 3-15  
DCP supervisor options 3-16  
DCP utilities 3-16  
DFA 3-12  
DIAGCOPY 3-12  
DIAGINIT 3-12  
diagnostic IPL 3-14  
diagnostic tests during concurrent maintenance  
    (LAN) 11-3  
diagnostic tests during IPL (LAN) 11-3  
diagnostic tests during on line problem determination  
    (LAN) 11-3  
diagnostic tests LAN 11-3  
disk 1-8, 8-3  
    exerciser 3-11  
disk drive 1-8, 8-3  
    problem determination 8-3  
    removals 8-11  
    replacements 8-11  
disk drive A maximum ripple voltage table 4-14  
disk drive B maximum ripple voltage table 4-14  
disk drive C maximum ripple voltage table 4-14  
disk drive D maximum ripple voltage table 4-15  
disk drive ERAP 8-4  
disk drive initialization 8-14  
disk drive isolation 8-5  
disk drive part numbers 8-11  
disk drive reload procedure 1-8  
disk failures 1-8, 8-3  
disk storage, alter/display 3-23  
diskette  
    drive removal 6-3  
    exerciser 3-11  
    voltage check 6-3  
diskette (SSP01) 3-10, 3-15  
diskette directory, list 3-16  
diskette drive maximum ripple voltage table 4-15

diskette failures 6-2  
diskette 61 3-10, 3-15  
diskette, disk attachment overview 2-5  
display  
    I/O controller storage 3-23  
display station exerciser 3-11  
display storage function 3-23  
display/alter 3-23  
    See also alter/display function  
    control storage 3-23  
    disk storage 3-23  
    main storage 3-23  
    MSP registers 3-23  
displaying storage 3-23  
distribution base DC voltage 4-11  
distribution feature DC voltage 4-12  
drive removal, diskette 6-3  
dump 3-7, 3-12

## E

EC level table, list 3-16  
EIA signal wraps 9-10  
electrostatic discharge/description C-1  
ERAP 3-11, 3-12, 3-25  
ERAP disk drive 8-4  
ESD C-1  
ESD handling kit C-1  
exercisers (SYSTEST)  
    communications 3-11  
    disk 3-11  
    diskette 3-11  
    display station 3-11  
    main storage 3-11  
    printer 3-11  
    tape 3-11

## F

failures  
    disk 1-8, 8-3  
    diskette 6-2  
    IPL 1-8, 8-3  
    twinax 7-15  
failures/main storage 1-13  
fan airflow cover  
    cover fan airflow 3-5  
fan removal 3-5  
fan replacement 3-5  
feature DC voltage distribution 4-12  
feature DC voltage tolerances 4-13  
feature I/O bus attachment overview 2-6  
feature power supply removal  
    removal feature power supply 4-3  
FRU isolation  
    diskette drive 6-2  
    IPL 1-8, 8-3  
    replacing disk drives 1-8

function A (Communications Line Status) 9-6, 9-7  
function 1 (IPL) 3-8  
function 2 (Reload) 3-9, 3-14  
function 3 (IPL Diagnostic Diskette) 3-8, 3-9  
function 3 (IPL Diagnostic Diskette) 3-14, 8-14  
function 4 (Dump) 3-7  
function 5 (System Reset) 3-7  
function 7 (Console Alter/Display) 3-23  
function 9 (Start CSP) 3-7  
function 3 (IPL diagnostic diskette) 8-5

## G

general safety training course B-1  
grounds, AC safety A-1  
guide, safety inspection B-1

## H

HISTCRT 3-12  
HISTORY 3-12

## I

I/O controller storage, alter/display 3-23  
IBM LPDA modem tests (COMMTST) 3-11  
IBM realtime interface co-processor 9-12  
IBM realtime interface co-processor rs-232-c electrical interface 9-14  
IBM realtime interface co-processor V.35 electrical interface 9-13  
ICFDEBUG 3-12  
ICVERIFY 3-12  
INIT 3-10, 3-12  
initial program load  
    See IPL  
inspection, safety B-1  
intermittent disk errors 1-8  
intermittent diskette drive errors 6-2  
IPL  
    DCP 3-14  
    diagnostic diskette 3-14  
    SSP 3-8  
IPL failures (disk) 1-8, 8-3  
isolating local area network problems 11-2  
isolating main storage problems 1-13  
isolation disk drive 8-5  
isolation procedure power supply 4-6

## J

jumper and switch setup IBM realtime interface co-processor 9-12  
jumper select, diskette drive 6-3  
jumper setup binary synchronous communications 9-17  
jumper setup serial/parallel adapter 9-3

## L

labels, safety B-3  
lamp test 5-4  
LAN card 11-4  
LAN problems 11-2  
LAN tests diagnostic 11-3  
line status, communications 9-6, 9-7  
line voltage switch  
    switch line voltage  
        voltage switch line 4-2, 4-3  
list  
    control storage directory 3-16  
    diskette directory 3-16  
    EC level table 3-16  
    microcode level table 3-16  
    patch table 3-16  
    prerequisite list 3-16  
list records from disk 3-16  
list records from diskette 3-16  
load options 3-15  
    AUTO CONFIG 3-15  
    customize 3-10  
    DCP 3-15  
    INIT 3-15  
    reload 3-10  
    SSP 3-10  
    SSP reload 3-15  
loading DCP from disk 3-14  
loading DCP from diskette 3-14  
loading SSP 3-8  
local area network card 11-4  
local area network diagnostic tests 11-3  
local area network problems 11-2  
local work station problems 7-2  
locations  
    board 2-9, 2-10  
    B1 board 2-13  
    card 2-14  
    system 2-8  
    top card connectors 2-11, 2-12  
    voltage table 4-11, 4-12, 4-13  
    voltage tolerances 4-13  
log, service F-1  
logic cards, ESD-sensitive C-1

## M

main storage  
    exerciser 3-11  
main storage/alter/display 3-23  
main storage/problems 1-13  
maximum minimum voltage tolerances 4-13  
maximum ripple voltage table A1 board 4-13  
metering procedure for twinax 7-15  
microcode level table, list 3-16  
minimum maximum voltage tolerances 4-13

## N

- network analysis 3-16
  - See also utilities
- network analysis procedure 7-2
- network local area problems 11-2

## O

- OFF 3-12
- ohmmeter test, cable 7-15
- on line problem determination, communications 9-4
- on line tests
  - BSC 9-8
  - BSCTEST 9-4
  - SDLC 9-9
  - SDLCTEST 9-4
- oscilloscope signals, cabling system 7-10
- oscilloscope signals, sample 7-10
- overview
  - channel 2-3
  - power 2-7
  - power point-to-point 4-9
  - tape attachment 2-6
- overview/diskette, disk attachment 2-5
- overview/processing unit 2-3
- overview/system 2-2
- overview/work station attachment 2-4

## P

- part numbers disk drives 8-11
- PATCH 3-12
- patch disk or diskette 3-16
- patch table, list 3-16
- pins, signal 9-13, 9-14
  - EIA 9-10
- power
  - AC point-to-point 4-10
  - FRU removals 4-6
- power cord safety B-2
- power FRUs
  - power supply 4-6
- power isolation procedure 4-6
- POWER OFF 3-12
- power overview 2-7
- prerequisite list 3-16
- print data traces (COMMTEST) 3-11
- printer exerciser 3-11
- PROBLEM 3-12, 9-4, 11-2, 11-3
- PROBLEM (problem determination) 3-11
- problem determination
  - control panel 5-4
  - disk drive 8-3
  - diskette voltage 6-3
  - local work station cable 7-3, 7-15
  - local work stations 7-2
- problem isolation
  - diskette drive 6-2

## problem isolation (continued)

- IPL 1-8, 8-3
  - replacing disk drives 1-8
- procedure 405 base power supply removal 4-2
- procedure 406 feature power supply removal 4-3
- procedure 410 power on/off actuator switch and cable check 4-4
- procedure 420 power supply FRU isolation
  - FRU isolation procedure 4-6
- procedure 505 control panel
  - symptom table 5-2
- procedure 507 control panel service check
  - control panel 5-4
- procedure 510 control panel
  - removal 5-9
- procedure 804 disk drive isolation 8-5
- procedures, SSP 3-12
  - See also SSP procedures
- processing unit and channel overview 2-3
- program patch
  - See also utilities
  - disk 3-16
  - diskette 3-16
  - free-lance 3-16
- PTF 3-12

## Q

- quality check signal cable 7-3

## R

- reinstall B1 board 3-17
- related publications iv
- reload options 3-10
- reloading SSP from diskettes 3-9
- reloading system microcode without auto configure 3-9
- remote loopback tests (COMMTEST) 3-11
- removal A1 board 3-19
- removal base power supply
  - base power supply removal 4-2
- removal B1 board 3-17
- removal, replace, check, power on/off actuator switch 4-4
- removals
  - control panel 5-9
  - diskette drive 6-3
- replace, removal, check, power on/off actuator switch 4-4
- REQUESTOR 9-8, 9-9
- RESPONDER 9-8, 9-9
- ripple maximum voltage table 4-13
- ripple maximum voltage table B1 board 4-14
- ripple maximum voltage table disk drive A 4-14
- ripple maximum voltage table disk drive B 4-14
- ripple maximum voltage table disk drive C 4-14
- ripple maximum voltage table disk drive D 4-15
- ripple maximum voltage table diskette drive 4-15

ripple maximum voltage table tape drive 4-15

RPQ 3-16

See also utilities

## S

safety grounds, AC A-1

safety inspection guide B-1

safety labels B-3

safety training course, general B-1

sample oscilloscope signals 7-10

SDLC and BSC EIA RS-232-C signal pins 9-10

SDLC on line test 9-9

SDLCTEST 9-2

SDLCTEST (SDLC on line test) 9-4, 9-9

SDLCTEST (SDLC online test) 3-11, 3-12

security switch 5-4

select jumper, diskette drive 6-3

serial parallel adapter 9-11

serial/parallel adapter jumper setup 9-3

SERVICE 3-12

service check

control panel 5-4

display key 5-4

input key 5-4

lamp test 5-4

power off/power on test 5-4

security switch test 5-4

select function key 5-4

service IPL 3-14

service log F-1

SERVLOG 3-12

SETCOMM 3-12, 9-5

SETDUMP 3-12

setup jumper binary synchronous communications 9-17

signal

pins 9-13, 9-14

EIA 9-10

wraps 9-13, 9-14

EIA 9-10

signal pins 9-11

signal wraps 9-13, 9-14

signals wrapped 9-11

signals, cabling system sample oscilloscope 7-10

SMF 3-12

SMFPRINT 3-12

SMFSTART 3-12

SMFSTOP 3-12

solvents, use of B-1

SSP load options 3-10

SSP procedures

ALTERCOM 3-12, 9-5

APAR 3-12

BSCTEST 3-11, 3-12, 9-2, 9-4, 9-8

BUILD 3-12

COMMTEST 3-11, 3-12, 9-2, 9-4

COPY11 3-12

D C or STATUS COMM 3-12

SSP procedures (continued)

D H or STATUS COMCNFIG 3-12

DFA 3-12

DIAGCOPY 3-12

DIAGINIT 3-12

DUMP 3-12

ERAP 3-11, 3-12, 3-25

HISTCRT 3-12

HISTORY 3-12

ICFDEBUG 3-12

ICVERIFY 3-12

INIT 3-12

OFF 3-12

PATCH 3-12

POWER OFF 3-12

PROBLEM 3-11, 3-12, 9-4

PTF 3-12

SDLCTEST 3-11, 3-12, 9-2, 9-4, 9-9

SERVICE 3-12

SERVLOG 3-12

SETCOMM 3-12, 9-5

SETDUMP 3-12

SMF 3-12

SMFPRINT 3-12

SMFSTART 3-12

SMFSTOP 3-12

START 3-12

STATEST 3-11, 3-12, 9-4

STOP 3-12

SYSTEST 3-11, 3-12, 3-25

TAPESTAT 3-12

TESTDSKT 3-12

TESTREQ 3-11, 3-12, 3-25

TRACE 3-12

VARY 3-12

START 3-12

start CSP 3-7

STATEST 11-2, 11-3

STATEST (station test) 3-11, 3-12, 9-4

static driver off test (COMMTEST) 3-11

static driver on test (COMMTEST) 3-11

status

communications 9-2

configuration 9-2

STATUS COMCNFIG 9-5

STATUS COMM 9-5

status, communications

configuration 9-5

line 9-6

STOP 3-12

supervisor options, DCP 3-16

supply power 4-6

switch power on/off actuator 4-4

system auto configuration 3-8

system configuration, automatic 3-8

system covers safety B-3

system customize 3-16

See also utilities

system dump 3-7  
system entry 1-5  
system locations 2-8  
system overview 2-2  
system records list 3-16

See also utilities

system reset 3-7

SYSTEST 3-12

ERAP 3-25

exercisers

communications 3-11

disk 3-11

diskette 3-11

display station 3-11

main storage 3-11

printer 3-11

tape 3-11

## T

tape

drive removal 10-2, 10-3

tape attachment overview 2-6

tape drive maximum ripple voltage table 4-15

tape exerciser 3-11

TAPESTAT 3-12

template, communications 9-7

test request (ERAP) 3-25

See also TESTREQ (test request)

test, cabling system 7-3

TESTDSKT 3-12

TESTREQ (test request) 3-11, 3-12, 3-25

tests LAN diagnostic 11-3

tolerances base and feature DC voltage 4-13

top card connectors 2-11, 2-12

TRACE 3-12

twinax

cable test 7-3, 7-15

metering 7-15

ohmmeter test 7-15

twinax/sample oscilloscope signals 7-10

## U

utilities

network analysis 3-16

program patch

disk 3-16

diskette 3-16

free-lance 3-16

RPQ 3-16

system customize 3-16

system records list

control storage directory 3-16

diskette directory 3-16

EC level table 3-16

microcode level table 3-16

patch table 3-16

prerequisite list 3-16

## V

VARY 3-12

voltage 4-11, 4-12

diskette voltage check 6-3

voltage measurement table 4-13

voltage table maximum ripple 4-13

Voltage tolerances 4-13

## W

warning notices vii

work station attachment overview 2-4

wrap tests, bypass 3-14

wrap tests, run 3-14

wraps, signal 9-13, 9-14

EIA 9-10



5363 System Unit  
Maintenance Information Manual

International Business Machines Corporation

Order Number  
SY31-9054-5